

# JVC

## SERVICE MANUAL

### STEREO INTEGRATED AMPLIFIER

### MODEL No. AX-222BK

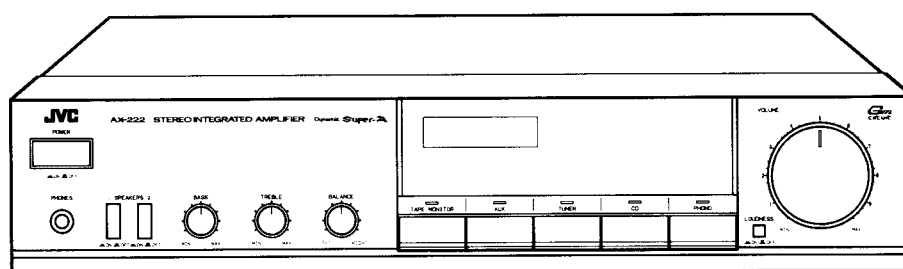

## Contents

	Page		Page
Safety Precautions.....	1-2	Adjustment Procedures .....	1-10
Specifications.....	1-3	Schematic Diagram .....	Insertion
Instruction Book .....	1-4	Internal Block Diagrams of ICs.....	Insertion
Block Diagram .....	1-8	Connection Diagram .....	Insertion
Removal Procedures.....	1-9	Parts List.....	Separate Volume Insertion

## Safety Precautions

1. The design of this product contains special hardware and may circuits and components specially for safety purposes. For continued protection, no changes should be made to the original design unless authorized in writing by the manufacturer. Replacement parts must be identical to those used in the original circuits. Service should be performed by qualified personnel only.
2. Alterations of the design or circuitry of the product should not be made. Any design alterations of the product should not be made. Any design alterations or additions will void the manufacturer's warranty and will further relieve the manufacturer of responsibility for personal injury or property damage resulting therefrom.
3. Many electrical and mechanical parts in the product have special safety-related characteristics. These characteristics are often not evident from visual inspection nor can the protection afforded by them necessarily be obtained by using replacement components rated for higher voltage, wattage, etc. Replacement parts which have these special safety characteristics are identified in the Parts List of Service Manual. Electrical components having such features are identified by shading on the schematics and by (  $\Delta$  ) on the Parts List in the Service Manual. The use of a substitute replacement which does not have the same safety characteristics as the recommended replacement part shown in the Parts List of Service Manual may create shock, fire, or other hazards.
4. The leads in the products are routed and dressed with ties, clamps, tubings, barriers and the like to be separated from live parts, high temperature parts, moving parts and/or sharp edges for the prevention of electric shock and fire hazard. When service is required, the original lead routing and dress should be observed, and it should be confirmed that they have been returned to normal, after re-assembling.
5. Leakage current check (Electrical shock hazard testing)

After re-assembling the product, always perform an isolation check on the exposed metal parts of the product (antenna terminals, knobs, metal cabinet, screw heads, headphone jack, control shafts, etc.) to be sure the product is safe to operate without danger of electrical shock.

Do not use a line isolation transformer during this check.

- Plug the AC line cord directly into the AC outlet. Using a "Leakage Current Tester", measure the leakage current from each exposed metal part of the cabinet, particularly any exposed metal part having a return path to the chassis, to a known good earth ground. Any leakage current must not exceed 0.5 mA AC (r.m.s.).
- Alternate check method

Plug the AC line cord directly into the AC outlet. Use an AC voltmeter having 1,000 ohms per volt or more sensitivity in the following manner. Connect a 1,500  $\Omega$  10 W resistor paralleled by a 0.15  $\mu$ F AC-type capacitor between an exposed metal part and a known good earth ground.

Measure the AC voltage across the resistor with the AC voltmeter.

Move the resistor connection to each exposed metal part, particularly any exposed metal part having a return path to the chassis, and measure the AC voltage across the resistor. Now, reverse the plug in the AC outlet and repeat each measurement. Any voltage measured must not exceed 0.75 V AC (r.m.s.). This corresponds to 0.5 mA AC (r.m.s.).

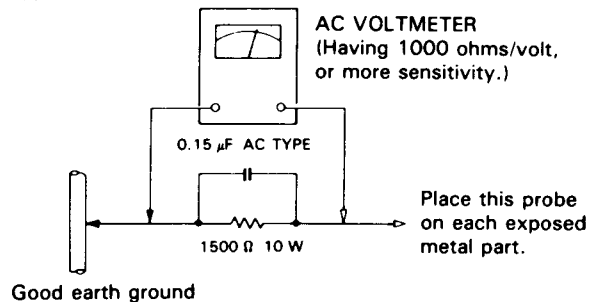

## Warning

1. This equipment has been designed and manufactured to meet international safety standards.
2. It is the legal responsibility of the repairer to ensure that these safety standards are maintained.
3. Repairs must be made in accordance with the relevant safety standards.
4. It is essential that safety critical components are replaced by approved parts.
5. If mains voltage selector is provided, check setting for local voltage.

# Specifications

## OVERALL CHARACTERISTICS

Output power : 40 watts per channel into 8 ohms at 1 kHz (DIN).

35 watts per channel, min. RMS, both channels driven, into 8 ohms from 40 Hz to 20 kHz, with no more than 0.007% total harmonic distortion.

35 watts per channel, min. RMS, both channels driven, into 8 ohms at 1 kHz with no more than 0.003% total harmonic distortion. (measured by JVC Audio Analyzer System)

- Total harmonic distortion : 0.007% (40 Hz – 20 kHz, 8 ohms) at 35 watts
- Intermodulation distortion : 0.007% (60 Hz: 7 kHz = 4 : 1, 8 ohms) at 35 watts
- Power band width : 7 Hz – 50 kHz (IHF, 0.05%, 8 ohms both channels driven)
- Frequency response : 5 Hz – 80 kHz +0, –3 dB (8 ohms)
- Damping factor : 35 (1 kHz, 8 ohms)
- Input terminals
- Input sensitivity/impedance (1 kHz)
  - PHONO : 2.5 mV/47 kohms
  - CD/AUX/ TUNER/TAPE : 150 mV/39 kohms
- Signal-to-noise ratio
  - PHONO : 71 dB ('66 IHF)
  - CD/AUX/ TUNER/TAPE MONITOR : 100 dB ('66 IHF)
  - PHONO (REC OUT) : 80 dB ('78 IHF)
  - CD/AUX/ TUNER/TAPE MONITOR (SP OUT) : 76 dB ('78 IHF)
  - PHONO : 67 dB (DIN)
  - CD/AUX/ TUNER/TAPE MONITOR : 68 dB (DIN)

- Tone controls : TREBLE: +8 ±1 dB –8 ±1 dB (at 10 kHz)
- BASS: +8 ±1 dB –8 ±1 dB (at 100 Hz)
- Loudness controls : +6 dB (at 100 Hz) (Volume control at –30 dB position) +4 dB (at 10 kHz)

## EQUALIZER

- PHONO overload capacity : 100 mV (0.02% THD)
- PHONO RIAA deviation : ±0.5 dB (20 Hz – 20 kHz)
- Recording output level/impedance : 150 mV/900 ohms

## GENERAL

- Dimensions : 435 (W) x 92 (H) x 252 (D) mm (17-3/16" x 3-5/8" x 7-15/16")
- Weight : 4.4 kg (9.7 lbs)
- Design and specifications subject to change without notice.

## POWER SPECIFICATIONS

Areas	Line Voltage & Frequency	Power Consumption
U.K.	AC 240 V ~, 50 Hz	220 watts
Australia		
Continental Europe	AC 220 V ~, 50 Hz	100 watts
Saudi Arabia	AC127 / 220 V ~ selectable, 50/60 Hz	
Other areas	AC 110 / 120 / 220 / 240 V ~ selectable, 50/60 Hz	

FRONT PANEL  
FRONTPLATTE  
PANNEAU AVANT

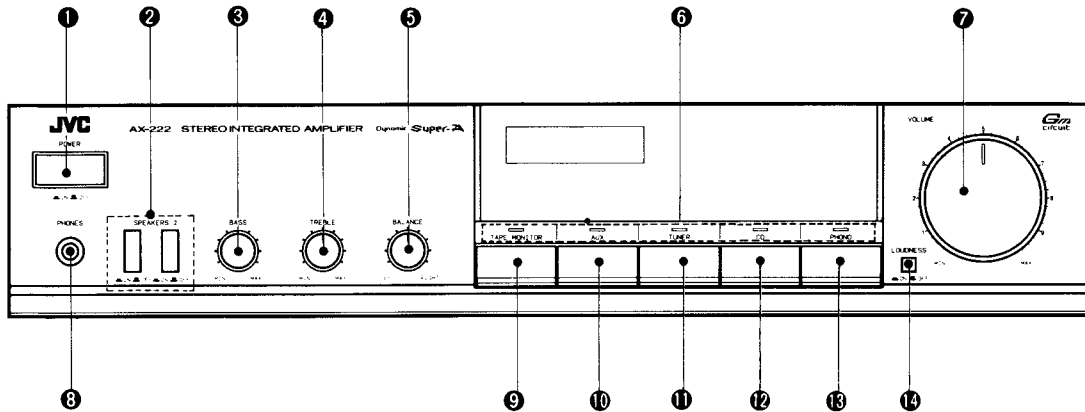

### 1 POWER

**ON ( — ):** Press this button to turn the power on.

**OFF ( ■ ):** Set to this position to turn the power off.

#### Notes:

- An electronic source selector is used in this unit. When the POWER button is first switched on, two or more sources or no source may be selected. Make sure to input the source select data by pressing one of the source selectors.
- When power is not supplied to this amplifier for 2 – 3 days, the source select button pressed before the power was switched off may be lost when the power is switched on again. If this happens, set the buttons, etc. again.
- If the POWER button is pressed repeatedly to switch on and off too quickly, the same phenomenon as the above will occur.

### 2 SPEAKERS

**1:** Press in ( — ) to listen to the speakers connected to the SPEAKERS SYSTEM-1 terminals.

**2:** Press in ( — ) to listen to the speakers connected to the SPEAKERS SYSTEM-2 terminals.

**1, 2:** Press 1 and 2 switches in ( — ) to listen to both speaker systems simultaneously.

**OFF:** Press 1 or 2 switch to set out ( ■ ) to turn off the corresponding speaker (for listening only through headphones, etc.)

#### Note:

- When speakers are connected to only one system of the SPEAKERS terminals, press only the SPEAKERS switch of that system connected; if both switches are pressed, sound will not be heard from either speaker system. When two pairs of speakers are connected and either or both SPEAKERS switches is/are pressed, sound will be heard from either or both speaker system(s).

### 1 Netzschalter (POWER)

**ON ( — ):** Diesen Schalter zum Einschalten des Geräts drücken.

**OFF ( ■ ):** Zum Ausschalten auf diese Position stellen.

#### Hinweise:

- Dieses Gerät besitzt einen elektronischen Signalquellen-Wahlschalter. Nachdem die Netzspannung eingeschaltet wurde, können zwei oder mehr Signalquellen bzw. keine Signalquelle gewählt werden. Durch Betätigen eines dieser Wahlschalter die erforderlichen Daten eingeben.
- Bleibt der Verstärker für 2 oder 3 Tage ohne Spannungsversorgung, ist die vor Ausschalten des Geräts gewählte Einstellung von Signalquellenwahl-Taste möglicherweise nicht mehr verfügbar. In diesem Fall die Einstellung erneut vornehmen.
- Wird die POWER-Taste in zu kurzen Abständen hintereinander ein- und ausgeschaltet, tritt das oben genannte Phänomen gleichfalls auf.

### 2 Lautsprecher (SPEAKERS)

**1:** Diese Taste drücken ( — ), um auf Wiedergabe über die an den SYSTEM-1-Buchsen angeschlossenen Lautsprecher zu schalten.

**2:** Diese Taste drücken ( — ), um auf Wiedergabe über die an den SYSTEM-2-Buchsen angeschlossenen Lautsprecher zu schalten.

**1, 2:** Beide Tasten drücken ( — ), um auf Wiedergabe über die an SYSTEM-1- und SYSTEM-2-Buchsen Lautsprecher zu schalten.

**OFF:** Diese Taste drücken ( ■ ), um die Lautsprecher auszuschalten, so daß ausschließlich über Kopfhörer wiedergegeben wird.

#### Hinweis:

- Bei Anschluß von Lautsprechern an nur ein System der SPEAKERS-Buchsen, nur den SPEAKERS-Schalter dieses Systems einschalten. Werden beide Schalter gedrückt, ist keines der Lautsprecher-systeme eingeschaltet! Bei Anschluß von zwei Lautsprecherpaaren ist, entsprechend der Bedienung der SPEAKERS-Schalter, die Übertragung über je eines oder beide Lautsprechersysteme möglich.

### 1 Interrupteur d'alimentation (POWER)

**ON ( — ):** L'enfoncer pour fournir l'alimentation.

**OFF ( ■ ):** L'enfoncer sur cette position pour couper l'alimentation.

#### Remarques:

- Un sélecteur de source électronique est utilisé dans cet appareil. Quand l'interrupteur POWER est mis marche, deux sources, plus de deux ou aucune source risquent d'être sélectionnées. S'assurer de bien mettre en entrée les données de sélection de source en enfonçant l'un des sélecteurs de source.
- Quand l'alimentation n'est pas fournie pendant 2 à 3 jours le sélecteur de source enfoncé avant que l'alimentation n'ait été coupée risquent d'être perdus quand l'alimentation est à nouveau fournie. Dans ce cas, régler à nouveau les touches, etc.
- Si l'interrupteur POWER est enfoncé plusieurs fois de suite pour fournir et couper l'alimentation trop rapidement, le même phénomène que ci-dessus se produira.

### 2 Haut-parleurs (SPEAKERS)

**1:** L'enfoncer ( — ) pour écouter les haut-parleurs raccordés aux bornes SPEAKERS SYSTEM-1.

**2:** L'enfoncer ( — ) pour écouter les haut-parleurs raccordés aux bornes SPEAKERS SYSTEM-2.

**1, 2:** Enfoncer les commutateurs 1 et 2 sur ( — ) pour écouter simultanément les deux systèmes de haut-parleurs.

**OFF:** Enfoncer le commutateur 1 ou 2 sur ( ■ ) pour mettre hors circuit le haut-parleur correspondant (pour n'écouter que par le casque d'écoute, etc.).

#### Remarque:

- Quand les haut-parleurs sont raccordés à un seul ensemble des bornes SPEAKERS, n'enfoncer que le commutateur SPEAKERS de l'ensemble raccordé; si les deux commutateurs sont enfoncés, le son ne sera audible d'aucun des haut-parleurs. Quand deux paires de haut-parleurs sont raccordées et que l'un ou les deux commutateurs SPEAKERS est/sont enfoncé(s), le son sera audible de l'une ou des deux paires de haut-parleurs.

**3 BASS**

Turn clockwise to boost bass response and counterclockwise to decrease it.

**4 TREBLE**

Turn clockwise to boost treble response and counterclockwise to decrease it.

**5 BALANCE**

Use to adjust the balance between the left and right speakers.

**6 SOURCE INDICATOR**

By pressing the buttons **9** – **13** respective LEDs light up. They also light up when the tape monitor button is pressed. In this case, the tape monitor button will have the priority.

**7 VOLUME**

Turn clockwise for louder sound.

**8 Headphone jack (PHONES)**

Plug stereo headphones into this jack for private listening.

**9 TAPE MONITOR**

Press in to listen to a tape played on a tape deck connected to the TAPE terminals. If your tape deck is a three-head deck, you can monitor the sound that has just been recorded on the tape. To release this function, press it again.

**10 AUX**

Press to listen to the source connected to the AUX terminals.

**11 TUNER**

Press in to listen to broadcasts.

**12 CD**

Press in to listen to a source connected to the CD terminals.

**13 PHONO**

Press in to listen to records.

**14 LOUDNESS**

Press this switch ON (  ) to compensate for the ear's different sensitivity to sound at low volumes.

**3 Bassregler (BASS)**

Im Uhrzeigersinn werden die Tieftonfrequenzen verstärkt, gegen den Uhrzeigersinn abgedämpft.

**4 Höhenregler (TREBLE)**

Im Uhrzeigersinn werden die hohen Frequenzen verstärkt, gegen den Uhrzeigersinn abgedämpft.

**5 Balanceregler (BALANCE)**

Für Balanceregulierung zwischen linkem und rechtem Lautsprecher.

**6 Quellenanzeige (SOURCE INDICATOR)**

Beim Drücken der Tasten **9** – **13**, die entsprechenden LEDs leuchten auf. Sie leuchten auf auch wenn die Band-Monitor-Taste gedrückt wird. In diesem Falle, hat die Band-Monitor-Taste den Vorrang.

**7 Lautstärke (VOLUME)**

Zur Erhöhung der Lautstärke im Uhrzeigersinn drehen.

**8 Kopfhörer-Buchse (PHONES)**

Zum Anschluß von Kopfhörern.

**9 Band-Monitor (TAPE MONITOR)**

Zur Wiedergabe einer Bandaufnahme von einem an den TAPE-Buchsen angeschlossenen Tape-Deck. Verfügt das angeschlossene Tape-Deck über drei Tonköpfe, ist Hinterbandkontrolle möglich. Nochmals drücken, um diese Funktion abzuschalten.

**10 AUX**

Zum Anhören der an die AUX-Klemmen angeschlossenen Tonquelle diese Taste drücken.

**11 Tuner (TUNER)**

Zur Wiedergabe von Radiosendungen drücken.

**12 CD**

Zur Wiedergabe einer an die CD-Klemmen angeschlossenen Signalquelle drücken.

**13 Phono (PHONO)**

Zur Wiedergabe von Schallplatten drücken.

**14 Lautstärkekontur (LOUDNESS)**

Diese Taste einschalten (  ), um die bei niedriger Lautstärke veränderte Empfindlichkeit des Gehörs zu kompensieren.

**3 Bases (BASS)**

Tourner dans le sens des aiguilles d'une montre pour augmenter la réponse des basses et dans le sens contraire pour la diminuer.

**4 Aiguës (TREBLE)**

Tourner dans le sens des aiguilles d'une montre pour augmenter la réponse des aiguës et dans le sens contraire pour la diminuer.

**5 Balance (BALANCE)**

Utilisée pour régler la balance entre les haut-parleurs de gauche et de droite.

**6 Indicateur de source (SOURCE INDICATOR)**

En enfonceant les touches **9** – **13**, le LED respectives s'illuminent. Elles s'illuminent aussi lorsque la touche de contrôle de bande est enfoncée. Dans ce cas, la touche de contrôle de bande aura priorité.

**7 Volume (VOLUME)**

La tourner dans le sens des aiguilles d'une montre pour augmenter le volume sonore.

**8 Prise de casque d'écoute (PHONES)**

Y raccorder un casque d'écoute stéréo pour une écoute privée.

**9 Contrôle de bande (TAPE MONITOR)**

L'enfoncer pour écouter une bande lue sur une platine d'enregistrement raccordée aux bornes TAPE. Si votre platine a trois têtes, vous pouvez contrôler le son qui vient d'être enregistré sur la bande. Pour dégager cette fonction, enfoncer cette touche à nouveau.

**10 AUX**

Appuyer sur cette touche pour écouter la source raccordée aux bornes AUX.

**11 Syntoniseur (TUNER)**

L'enfoncer pour écouter des émissions radiodiffusées.

**12 Disque audionumérique (CD)**

L'enfoncer pour écouter une source raccordée aux bornes CD.

**13 Platine tourne-disque (PHONO)**

L'enfoncer pour écouter des disques.

**14 Contour (LOUDNESS)**

Enfoncer ce commutateur (  ) pour compenser la sensibilité différente de l'oreille à de faibles volumes.

## OPERATION

### Listening to broadcasts

1. Connect a tuner to the TUNER terminals on the rear panel.
2. Press the POWER button to on (  ).
3. Select the speaker system with the SPEAKERS switches.
4. Press the TUNER button to on.
5. Operate the tuner according to its instruction book.
6. Adjust the VOLUME, LOUDNESS, BALANCE, BASS and TREBLE controls as required.

### Listening to records

1. Connect a turntable to the PHONO terminals on the rear panel.  
Be careful to connect the channels correctly.
2. Press the POWER button to on (  ).
3. Select the speaker system with the SPEAKERS switches.
4. Press the PHONO button to on.
5. Operate the turntable according to its instruction book.
6. Adjust the VOLUME, LOUDNESS, BALANCE, BASS and TREBLE controls as required.

#### Note:

- Use a turntable with a moving magnet cartridge.

### Listening to tapes

1. Connect a tape deck to the TAPE PLAY terminals.
2. Press the POWER button to on (  ).
3. Select the speaker system with the SPEAKERS switches.
4. Press the TAPE MONITOR button to on.
5. Operate the tape deck for playback according to its instruction manual.
6. Adjust the VOLUME, LOUDNESS, BALANCE, BASS and TREBLE controls as required.

#### Note:

- Don't place the tape deck directly on or under the amplifier. Otherwise, over as heating or hum may result.

### Using stereo headphones

Stereo headphones can be plugged into the front panel jack.

### Recording from records

1. Connect a tape deck to the TAPE REC terminals.
2. Press the POWER button to on (  ).
3. Select the speaker system with the SPEAKERS switches if you want to monitor the sound while recording.
4. Press the PHONO button to on.
5. Operate the turntable.
6. Operate the tape deck for recording.

## BEDIENUNG

### Wiedergabe von Radiosendungen

1. Einen Tuner an die TUNER-Buchsen an der Rückplatte anschließen.
2. Die Netzspannung mit der POWER-Taste einschalten (  ).
3. Mit dem SPEAKERS-Schalter das gewünschte Lautsprechersystem einschalten.
4. Die TUNER-Taste drücken.
5. Den Tuner entsprechend dessen Anleitung bedienen.
6. Die VOLUME, LOUDNESS, BALANCE- und BASS- und TREBLE-Bedienungselemente wie gewünscht einstellen.

### Wiedergabe von Schallplatten

1. Einen Plattenspieler an die PHONO-Buchsen der Rückplatte anschließen, und dabei auf korrekten Anschluß der Kanäle achten.
2. Die Netzspannung mit der POWER-Taste einschalten (  ).
3. Mit dem SPEAKERS-Schalter das gewünschte Lautsprechersystem einschalten.
4. Die PHONO-Taste drücken.
5. Den Plattenspieler entsprechend dessen Anleitung bedienen.
6. Die VOLUME, LOUDNESS, BALANCE, BASS- und TREBLE-Regler wie gewünscht einstellen.

#### Hinweis:

- Einen Plattenspieler mit Magnet-Tonabnehmersystem benutzen.

### Wiedergabe von Bandaufnahmen

1. Ein Tape-Deck an den TAPE-Buchsen anschließen.
2. Die Netzspannung mit der POWER-Taste einschalten (  ).
3. Mit dem SPEAKERS-Schalter das gewünschte Lautsprechersystem einschalten.
4. Die TAPE MONITOR-Taste drücken.
5. Das Tape-Deck entsprechend dessen Anleitung bedienen.
6. Die VOLUME, LOUDNESS, BALANCE, BASS- und TREBLE-Regler wie gewünscht einstellen.

#### Hinweis:

- Das Bandgerät nicht direkt über oder unter den Verstärker aufstellen, da ansonsten Wärme entsteht und Brummen hervorgerufen wird.

### Stereo-Kopfhörer-Anschluß

Stereo-Kopfhörer können in der Buchse an der Frontblende angeschlossen werden.

### Aufnahmen von Schallplatten

1. Ein Tape-Deck an die TAPE REC-Buchsen anschließen.
2. Die Netzspannung mit dem POWER-Taste einschalten (  ).
3. Mit dem SPEAKERS-Schalter das gewünschte Lautsprechersystem einschalten, falls bei der Aufnahme mitgehört werden soll.
4. Die PHONO-Taste drücken.
5. Den Plattenspieler bedienen.
6. Das Tape-Deck entsprechend dessen Anleitungen für Aufnahmebetrieb bedienen.

## FONCTIONNEMENT

### Ecoute d'émissions

1. Raccorder un syntoniseur aux bornes TUNER du panneau arrière.
2. Enfoncer la touche POWER (  ).
3. Sélectionner le système de haut-parleurs avec le sélecteur SPEAKERS.
4. Enfoncer la touche TUNER.
5. Faire fonctionner le syntoniseur selon les instructions de son manuel.
6. Régler les commandes VOLUME, LOUDNESS, BALANCE, BASS et TREBLE.

### Ecoute de disques

1. Raccorder une platine tourne-disque aux bornes PHONO du panneau arrière. S'assurer que les canaux sont bien raccordés.
2. Enfoncer la touche POWER (  ).
3. Sélectionner le système de haut-parleurs avec le sélecteur SPEAKERS.
4. Enfoncer la touche PHONO.
5. Faire fonctionner la platine tourne-disque selon les instructions de son manuel.
6. Régler les commandes VOLUME, LOUDNESS, BALANCE, BASS et TREBLE.

#### Remarque:

- Utiliser une platine tourne-disque à cellule à aimant mobile.

### Ecoute de bandes

1. Raccorder une platine d'enregistrement aux bornes TAPE PLAY.
2. Enfoncer la touche POWER (  ).
3. Sélectionner le système de haut-parleurs avec le sélecteur SPEAKERS.
4. Enfoncer la touche TAPE MONITOR.
5. Faire fonctionner la platine d'enregistrement en lecture selon les instructions de son manuel.
6. Régler les commandes VOLUME, LOUDNESS, BALANCE, BASS et TREBLE.

#### Remarque:

- Ne pas poser directement la platine cassette sur ou sous l'amplificateur. Sinon des ennuis tels que l'échauffement ou le ronflement de l'appareil en résulteraient.

### Utilisation d'un casque d'écoute stéréo

Un casque d'écoute stéréo peut être branché sur la prise du panneau avant.

### Enregistrement à partir de disques

1. Raccorder une platine d'enregistrement aux bornes TAPE REC.
2. Enfoncer la touche POWER (  ).
3. Sélectionner le système de haut-parleurs avec le sélecteur SPEAKERS, si vous voulez écouter le son tout en enregistrant.
4. Enfoncer la touche PHONO.
5. Faire fonctionner la platine tourne-disque.
6. Faire fonctionner la platine d'enregistrement en enregistrement.

**To record from other sources (TUNER, CD, AUX)**

Press the TUNER, CD or AUX button to record radio broadcasts, or the source connected to the CD, AUX terminals.

All other operations are identical as when you record from records.

**Notes:**

- You can also monitor the sound being recorded with headphones.
- The sound you hear from the speakers or headphones is the source sound, not that being recorded on the tape.
- The VOLUME control of this amplifier has no effect on the recording level. Adjust the recording level with the controls on the tape deck.
- While playing back a tape on the tape deck, you cannot record the sources from other components.

**How to operate the monitor while recording on the tape deck**

1. Connect a 3-head tape deck to the TAPE terminals.
2. Make sure to connect the signal cords to the PLAY and REC terminals.
3. Select the source from which you want to record by depressing the source select button on this unit.
4. Operate the tape deck for recording as described in its operating manual.
5. By playing the source component, you can record on the tape deck.
6. While recording on the tape deck, the recorded sound can be heard by depressing the TAPE MONITOR button on this unit.

**Aufnahmen von anderen Signalquellen (TUNER), CD-Plattenspieler (CD, AUX)**

Die Tuner-Taste (TUNER) drücken, um Radiosendungen aufzunehmen, und die CD-Plattenspieler-Taste (CD, AUX) drücken, um eine Signalquelle aufzunehmen, die mit den Anschlüssen für CD-Plattenspieler (CD, AUX) verbunden ist.

Wie bei Aufnahmen von Platten sind alle anderen Bedienungsvorgänge gleich.

**Hinweise:**

- Die Aufnahme kann auch über Kopfhörer überwacht werden.
- Den Ton, den Sie über die Lautsprecher oder den Kopfhörer vernehmen, ist der Klang der Signalquelle, und nicht der, der auf dem Band aufgenommen wird.
- Die Lautstärke-Einstellung (VOLUME) dieses Verstärkers hat keinen Einfluß auf den Aufnahmepegel. Stellen Sie den Aufnahmepegel mit den Lautstärke-Reglern des Kassettendecks ein.
- Während der Wiedergabe eines Bandes mit einem Kassettendeck (dieses Gerätes verbunden ist), können keine Tonquellen von anderen Komponenten aufgenommen werden.

**Verwendung der Monitorfunktion während einer Aufnahme mit einem Kassettendeck**

1. Das Drei-Kopf-Kassettendeck an die Kassette (TAPE) anschließen.
2. Vergewissern Sie sich, daß die Verbindungskabel an die Wiedergabe- (PLAY) und die Aufnahme-Buchsen (REC) angeschlossen sind.
3. Wählen Sie die gewünschte Signalquelle durch Drücken der Signalwähl-Taste an diesem Gerät.
4. Das Kassettendeck wie in der Betriebsanleitung angegeben in der Aufnahmefunktion betreiben.
5. Die abzuspielende Tonquelle kann nun mit dem Kassettendeck aufgenommen werden.
6. Während des Aufnahmeprozesses kann der Ton mitgehört werden – drücken Sie dazu die Kassette Monitor (TAPE MONITOR) an diesem Gerät.

**Enregistrement à partir d'autres sources (TUNER, CD, AUX)**

Enfoncer le commutateur TUNER, CD ou AUX pour enregistrer des émissions radio ou la source raccordée aux bornes CD, AUX.

Tous les autres opérations sont identiques à celles de l'enregistrement à partir de disques.

**Remarques:**

- Vous pouvez aussi contrôler le son enregistré avec le casque d'écoute.
- Le son que vous entendez des haut-parleurs ou du casque est le son de la source et non pas le son enregistré sur la bande.
- La commande VOLUME de cet amplificateur n'a pas d'effet sur le niveau d'enregistrement. Régler celui-ci avec les commandes de la platine.
- Lors de la lecture d'une bande sur la platine d'enregistrement, il est impossible d'enregistrer les signaux d'entrée en provenance d'autres éléments.

**Comment utiliser le contrôle auditif lors d'un enregistrement sur la platine d'enregistrement**

1. Connecter la platine d'enregistrement à 3 têtes aux bornes TAPE.
2. Veiller à bien connecter les cordons aux bornes pour lecture (PLAY) et pour enregistrement (REC).
3. Sélectionner l'élément d'entrée que l'on désire enregistrer en enfonçant une touche du sélecteur d'entrée de cet appareil.
4. Faire fonctionner l'élément d'entrée comme décrit dans son mode d'emploi.
5. Il est alors possible d'effectuer l'enregistrement sur la platine d'enregistrement tout en écoutant l'élément d'entrée.
6. Tout en enregistrant sur la platine d'enregistrement, il est possible d'écouter le son enregistré en enfonçant la touche TAPE MONITOR.

# Block Diagram

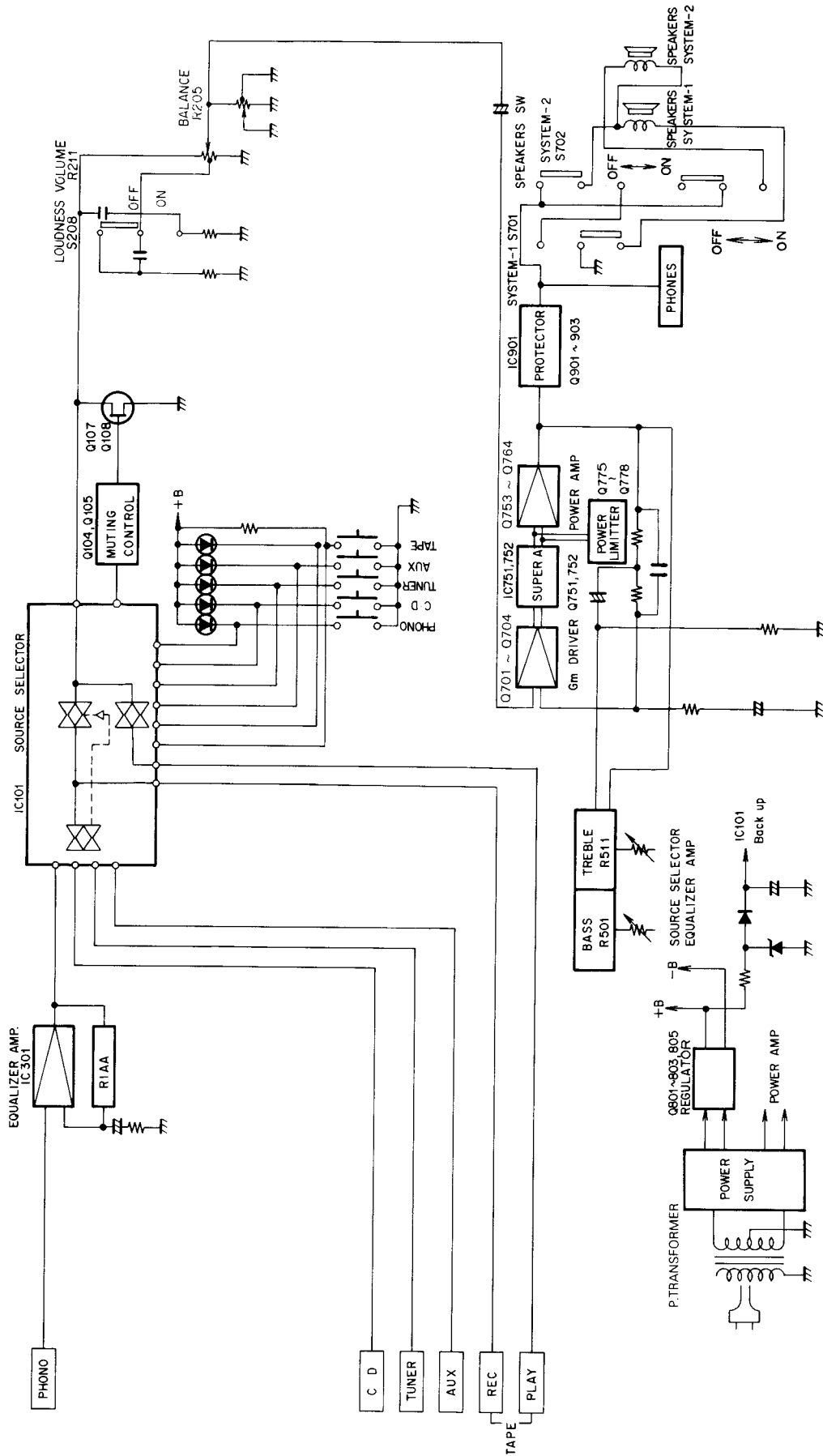



## Removal Procedures

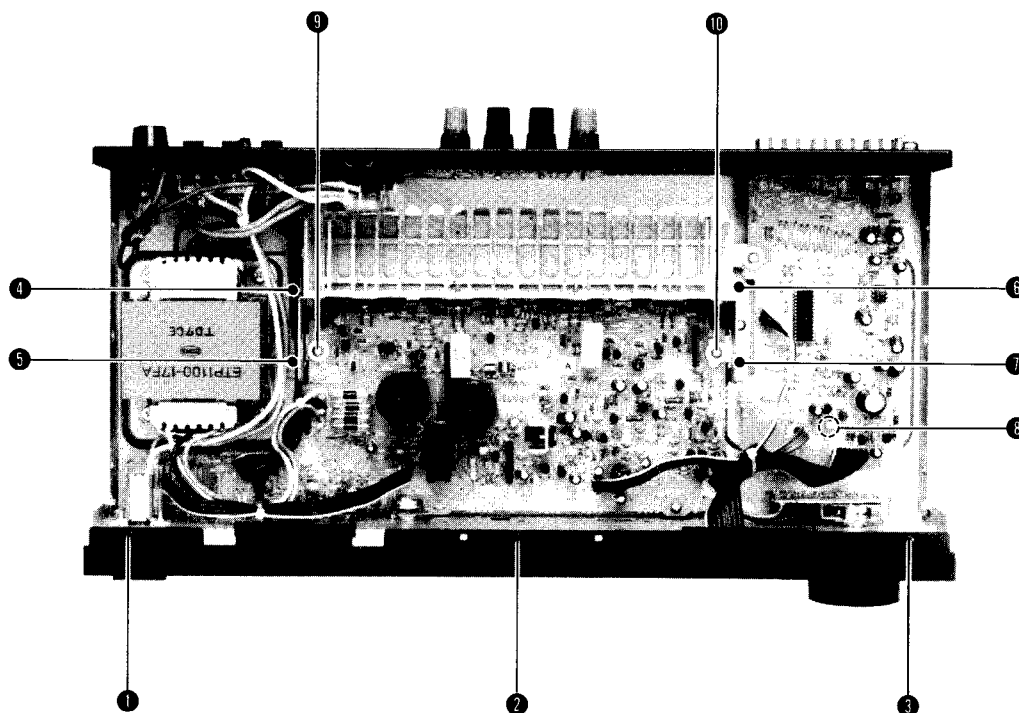

### ■ Removing the Top Cover

1. Remove six screws.
2. Remove the metal cover by lifting up its rear section and pulling it backward while holding it on incline.

### ■ Removing the Front Panel

1. Remove the top cover.
2. Remove plastic rivets ① - ③ and three screws from the lower part of the front panel.

### ■ Removing the Power Transistors

1. Remove the top cover.
2. Remove four screws securing the front bracket of the bottom side and four screws securing the rear panel.
3. Remove screws ④ - ⑦ to remove the PC board from fastener ⑧.
4. Keep the PC board a little away from the front panel and rear panel while pushing them toward you and the back side respectively and raise the PC board to the left (Power Transformer side.)

Under this condition, check the Source Select PC Board and Power Amplifier PC Board.

5. Remove solder from the power transistor (Q761-Q764).
6. Remove screws ⑨ and ⑩ and remove the heatsink.
7. Remove the defective power transistor from the heatsink and replace it.

### ■ Precautions when Installing the Volume Knob

When installing the main volume (R211), the volume knob should be pulled out. For installation, perform the next procedures.

1. After installing R211 to the front bracket, turn the volume shaft fully counterclockwise.
2. Insert the volume knob so that the projection part of its circumference faces right above.

## ■ Use of New-type Connector

(1) Slide the cover upward.

(2) Extract the wires.

(3) Insert the wires after pushing in the cover.

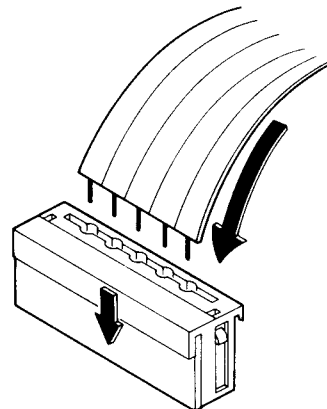
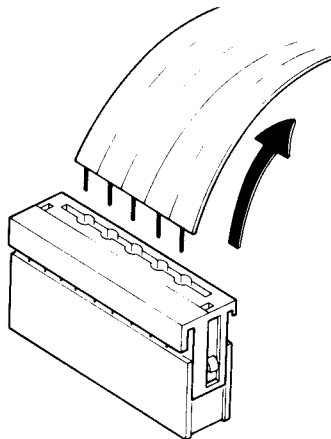
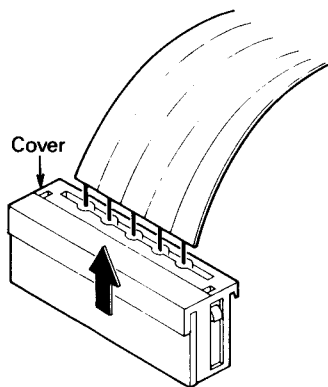

## Adjustment Procedures

### ■ Power Amplifier Idling Adjustment

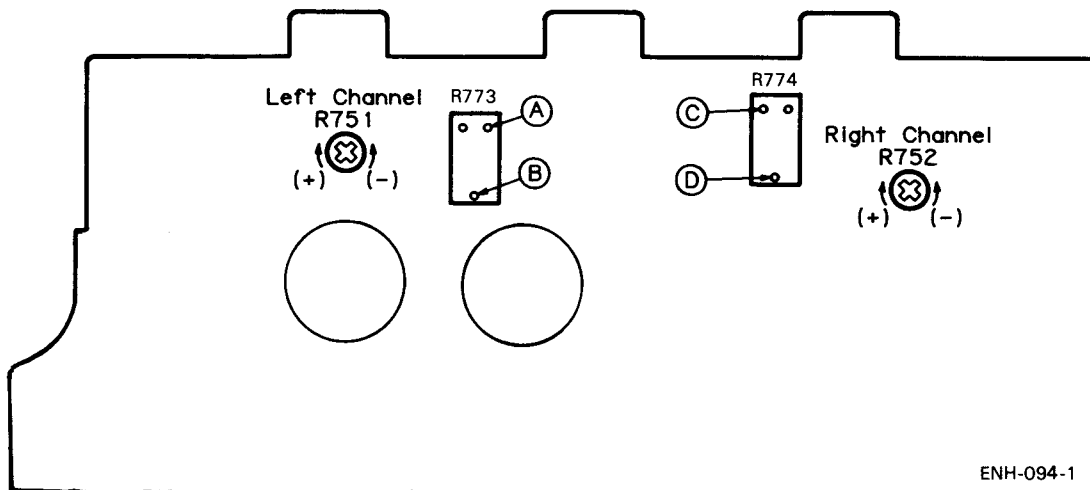

1. Before tuning on the power, turn the semi-fixed resistors (R751 for L channel and R752 for R channel) of the power amplifier circuit board fully counterclockwise.
2. Adjust the semi-fixed resistor (R751 and R752) so that the voltage at the following test points of the power amplifier circuit board is within a range of 3 ~ 5 mV after the power is turned on.
  - L channel: Measure the voltage between test point ① (emitter of Q761) and output at the test point ②.
  - R channel: Measure the voltage between test point ③ (emitter of Q762) and output at the test point ④.

3. Readjust resistors R751 and R752 about 10 minutes after the power is turned on (the heatsink temperature must be sufficiently high) so that the voltage at the test points becomes 11 mV.





Confirm that the voltage does not vary when the heat-sink temperature increases further.

**Note:** Be sure to perform the measurement with the probes and cabinet of the measuring equipment separated from the grounding terminals of AX-222BK or other measuring equipment.

# Schematic Diagram

ENH-094-2

**Notes:**

1.  shows DC voltage to the chassis with no signal input.
2.  indicates  $\pm$  B power supply.
3.  indicates signal path.
4. When replacing the parts in the darkened area (  ) and those marked with  $\Delta$ , be sure to use the designated parts to ensure safety.
5. This is the standard circuit diagram.  
The design and contents are subject to change without notice.

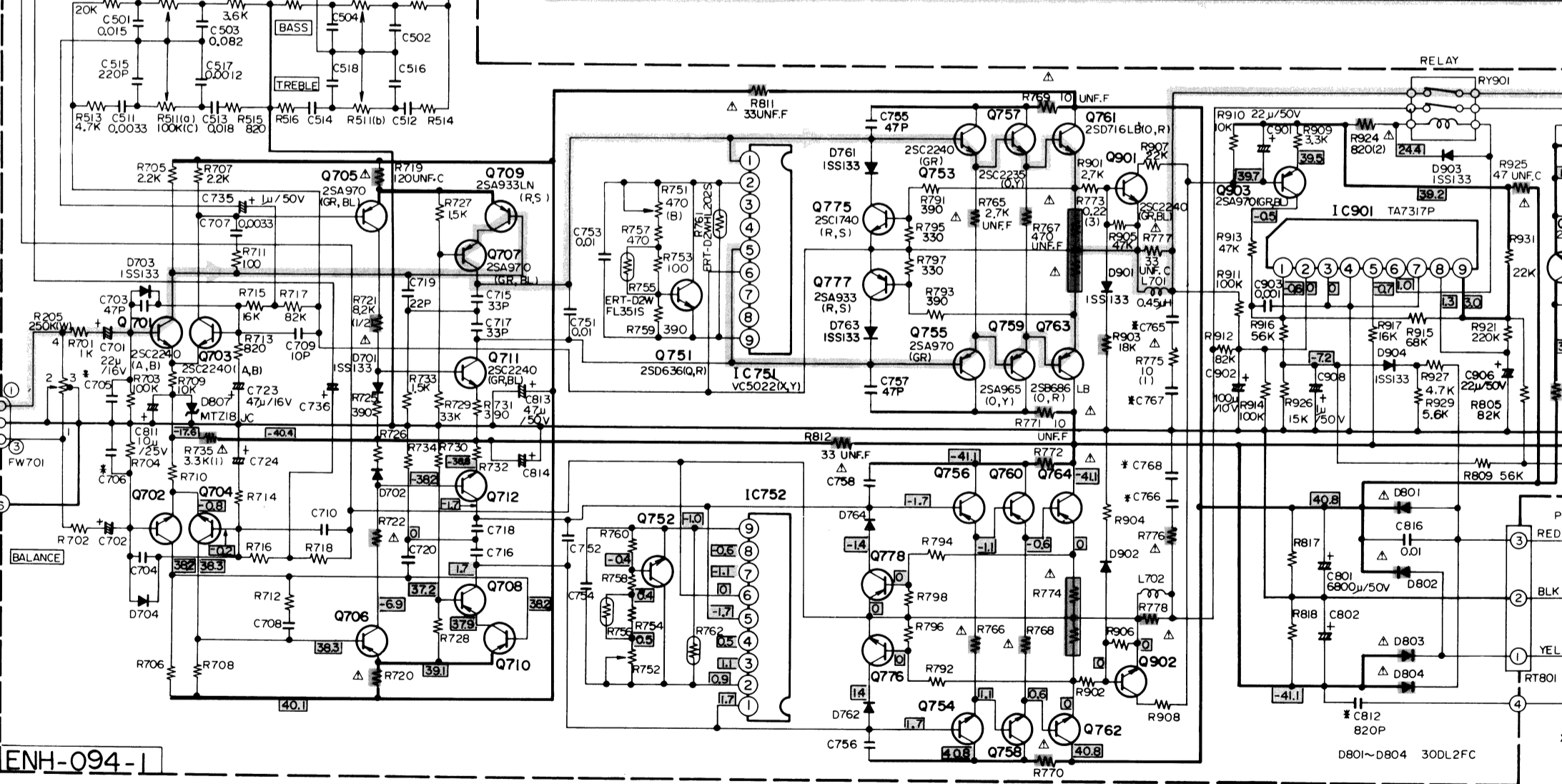
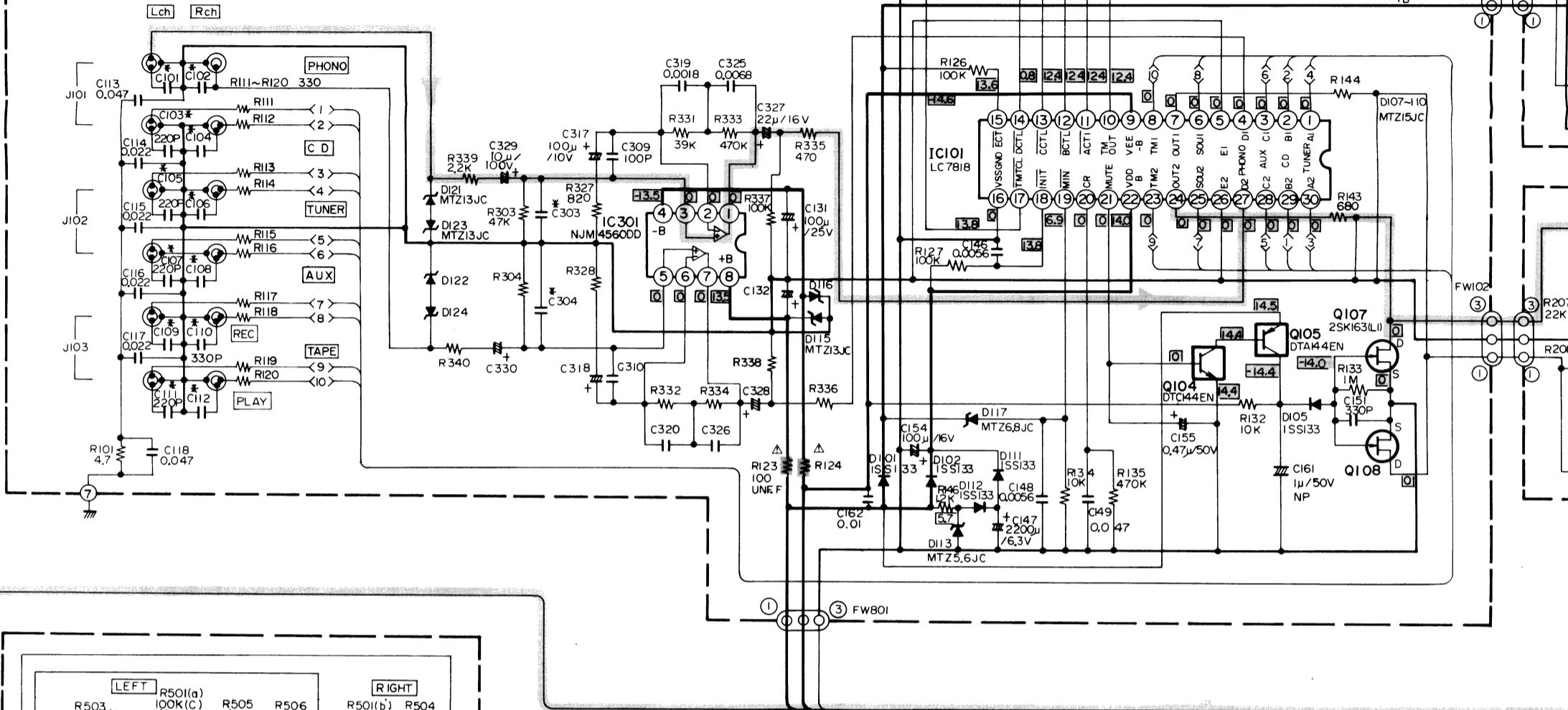

ENH-094-1

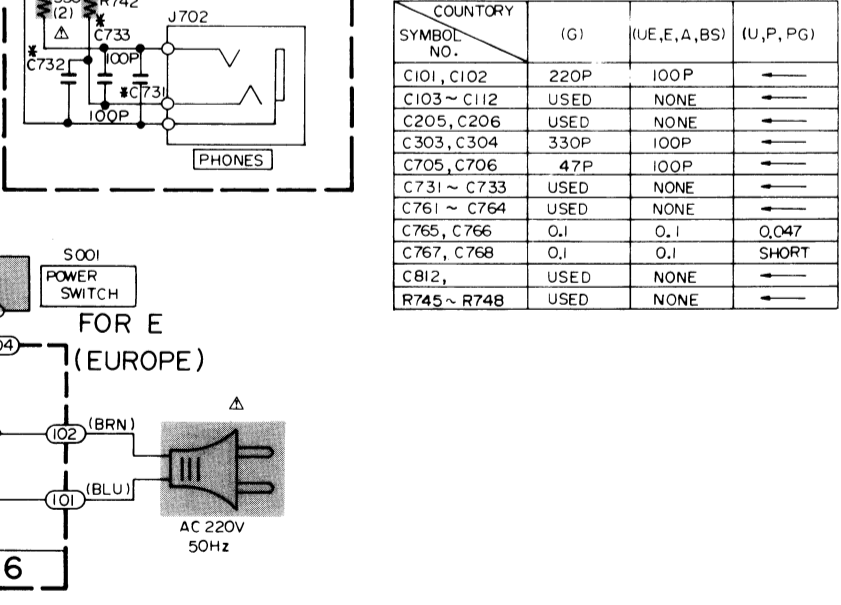
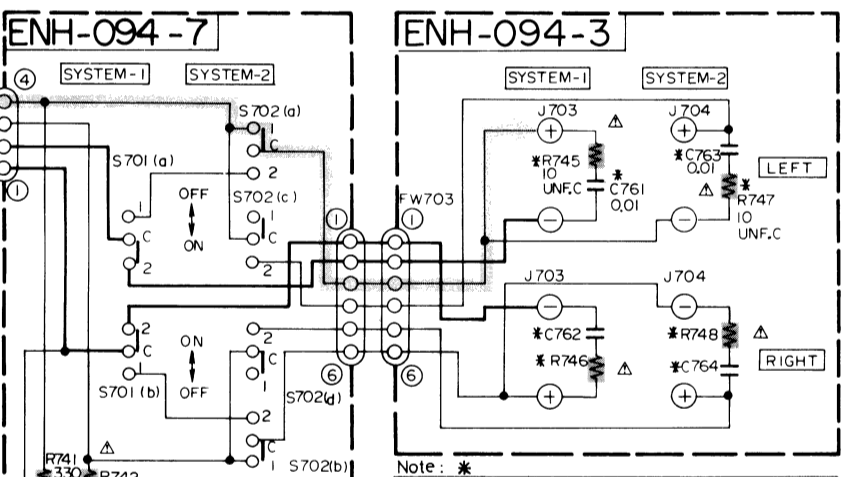
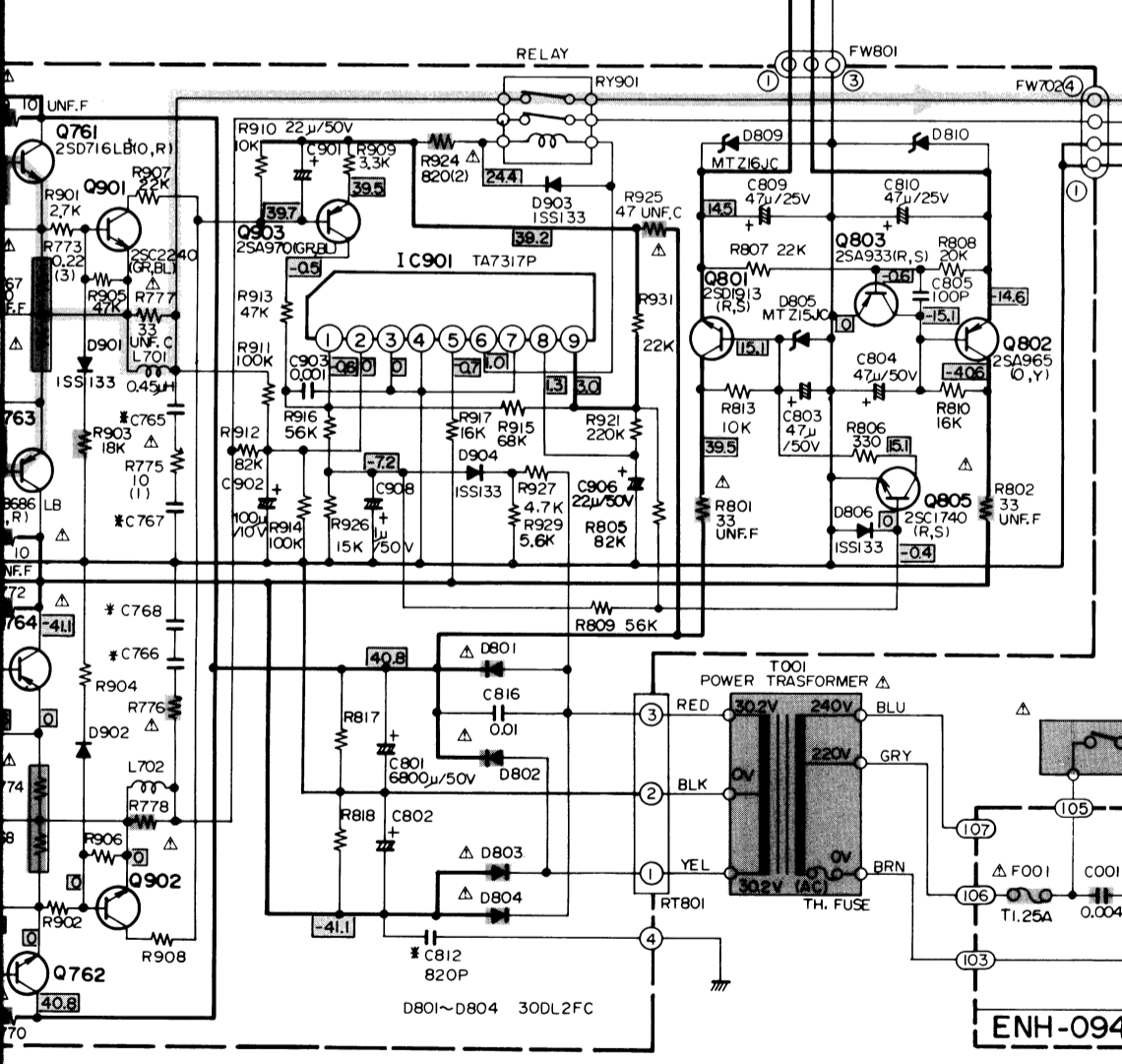
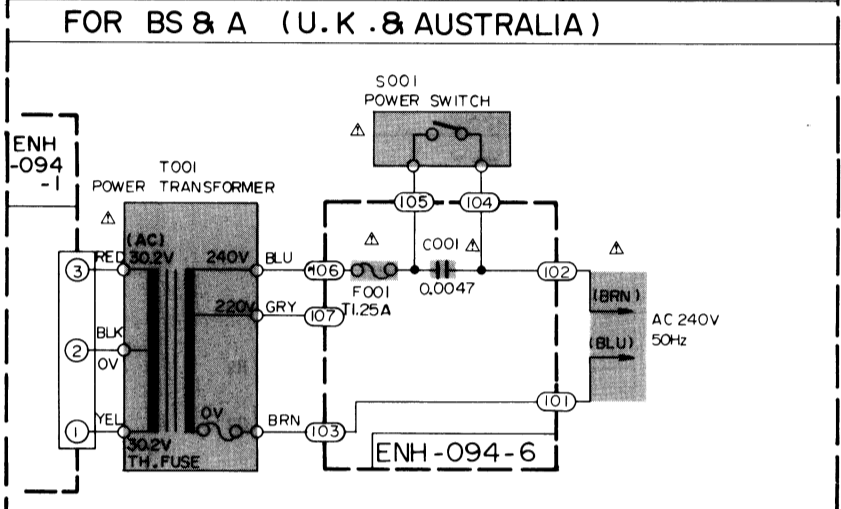
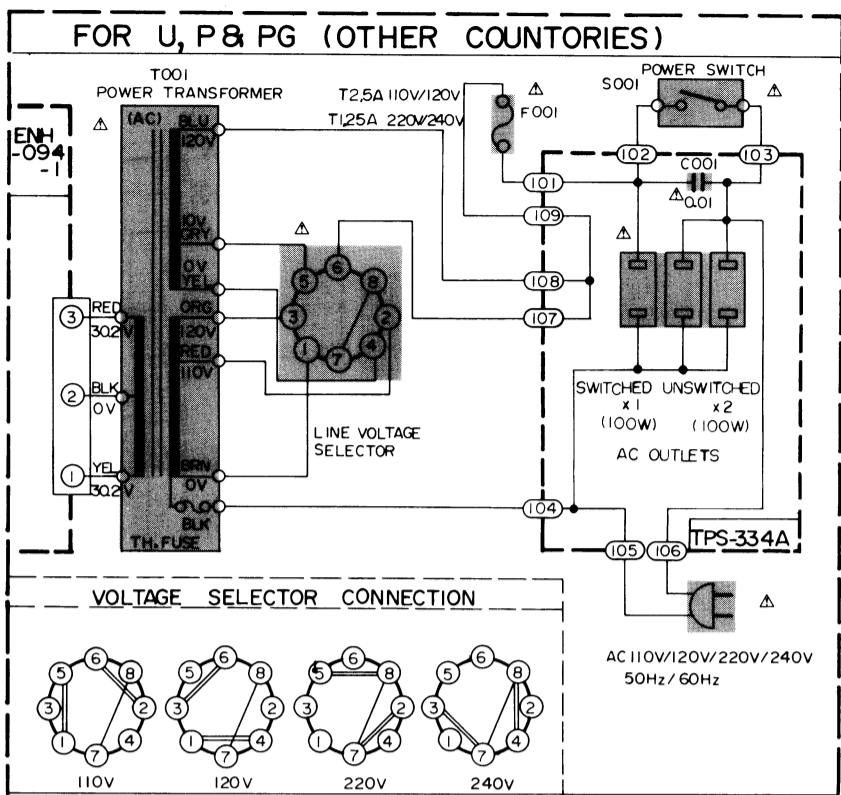
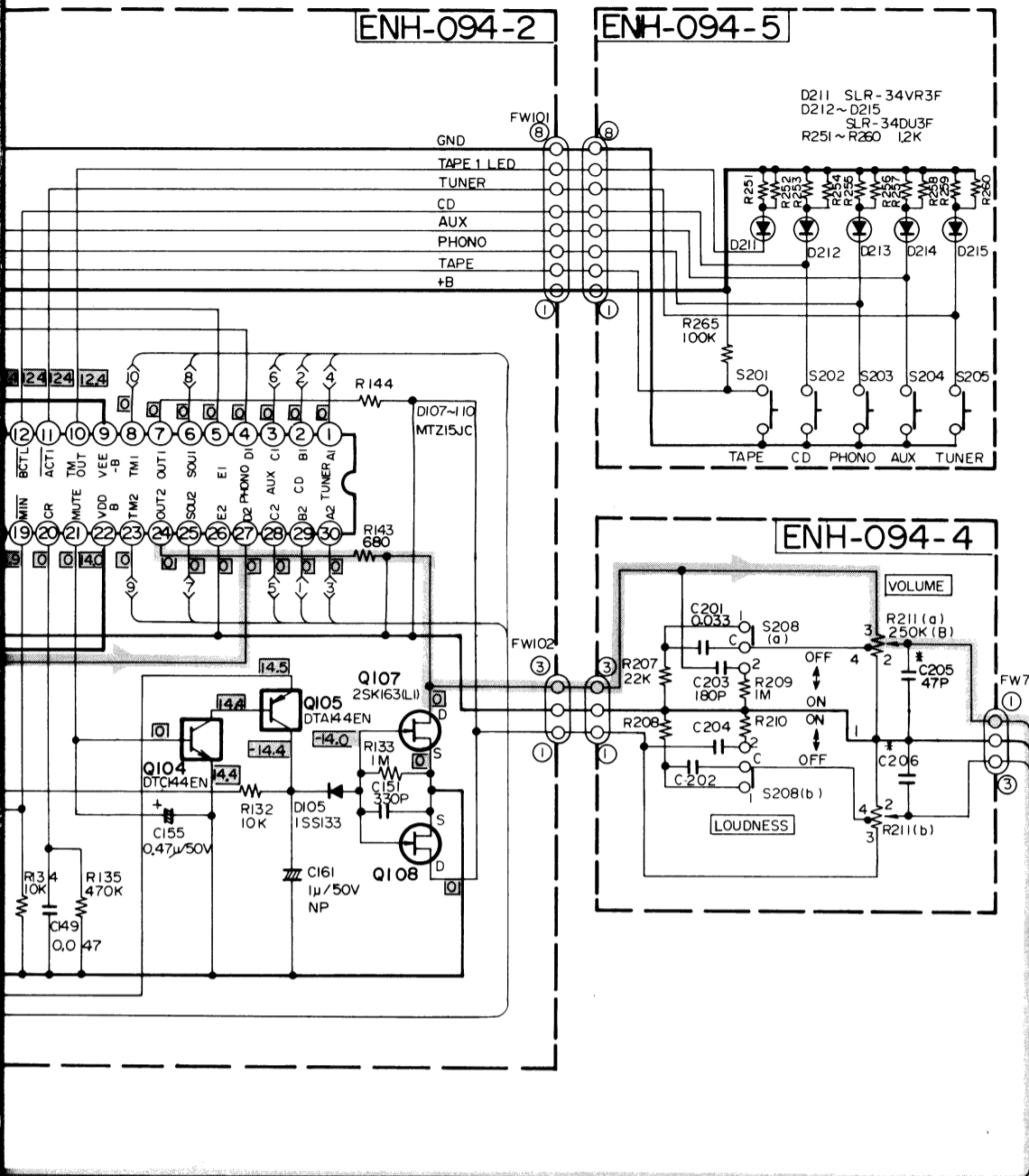

Note: \*

SYMBOL NO.	COUNTRY		
	(G)	(U,E,E,A,BS)	(U,P,PG)
C101, C102	220P	100P	←
C103 ~ C112	USED	NONE	←
C203, C206	USED	NONE	←
C303, C304	330P	100P	←
C705, C706	47P	100P	←
C731 ~ C733	USED	NONE	←
C761 ~ C764	USED	NONE	←
C765, C766	0.1	0.1	0.047
C767, C768	0.1	0.1	SHORT
C812	USED	NONE	←
R745 ~ R748	USED	NONE	←

# Schematic Diagram

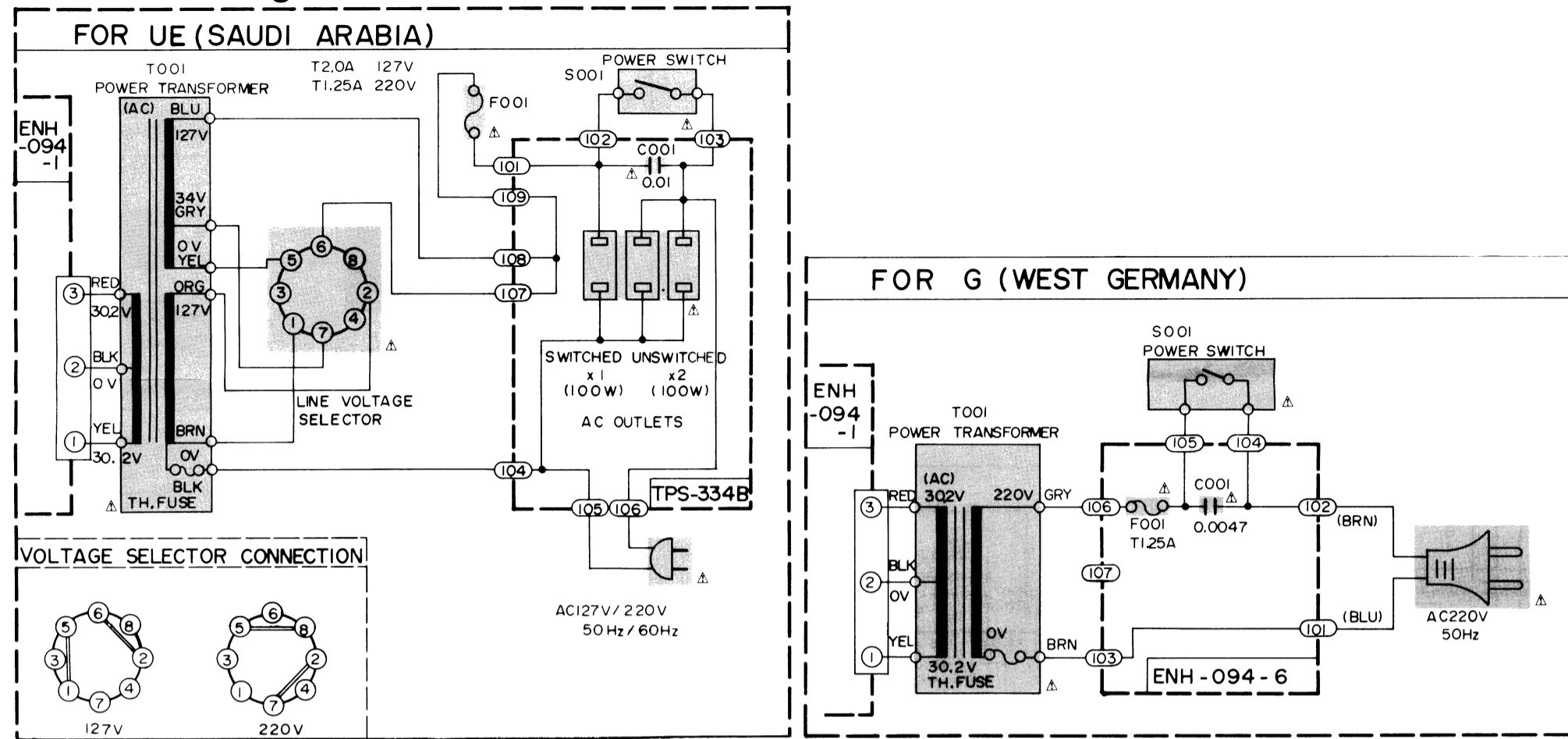

## Internal Block Diagrams of ICs

### ■ LC7818 (IC101)

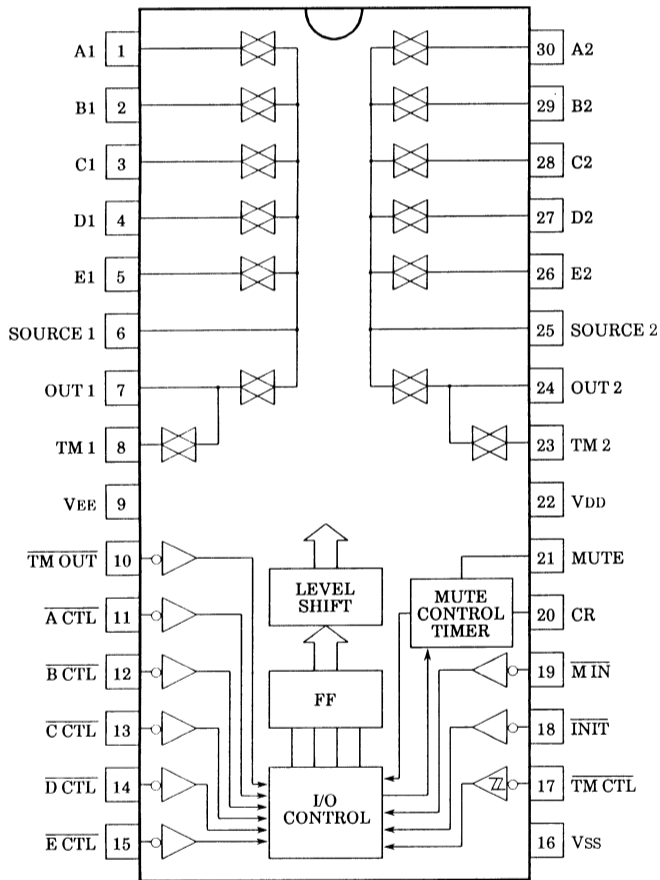

### ■ VC5022 [X, Y] (IC751, IC752)

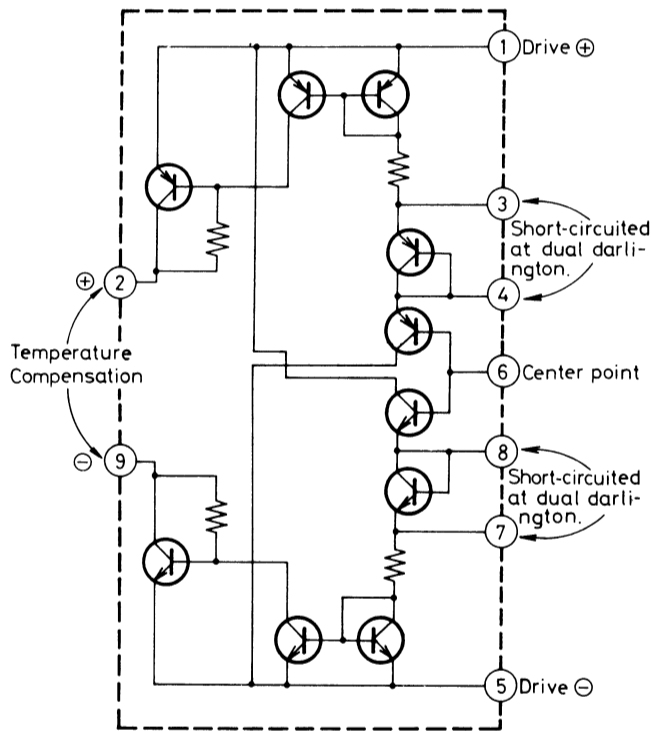

### ■ TA7317P (IC901)

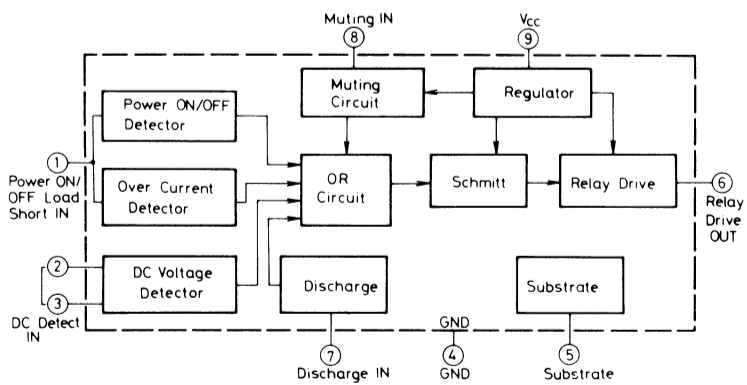

# Connection Diagram

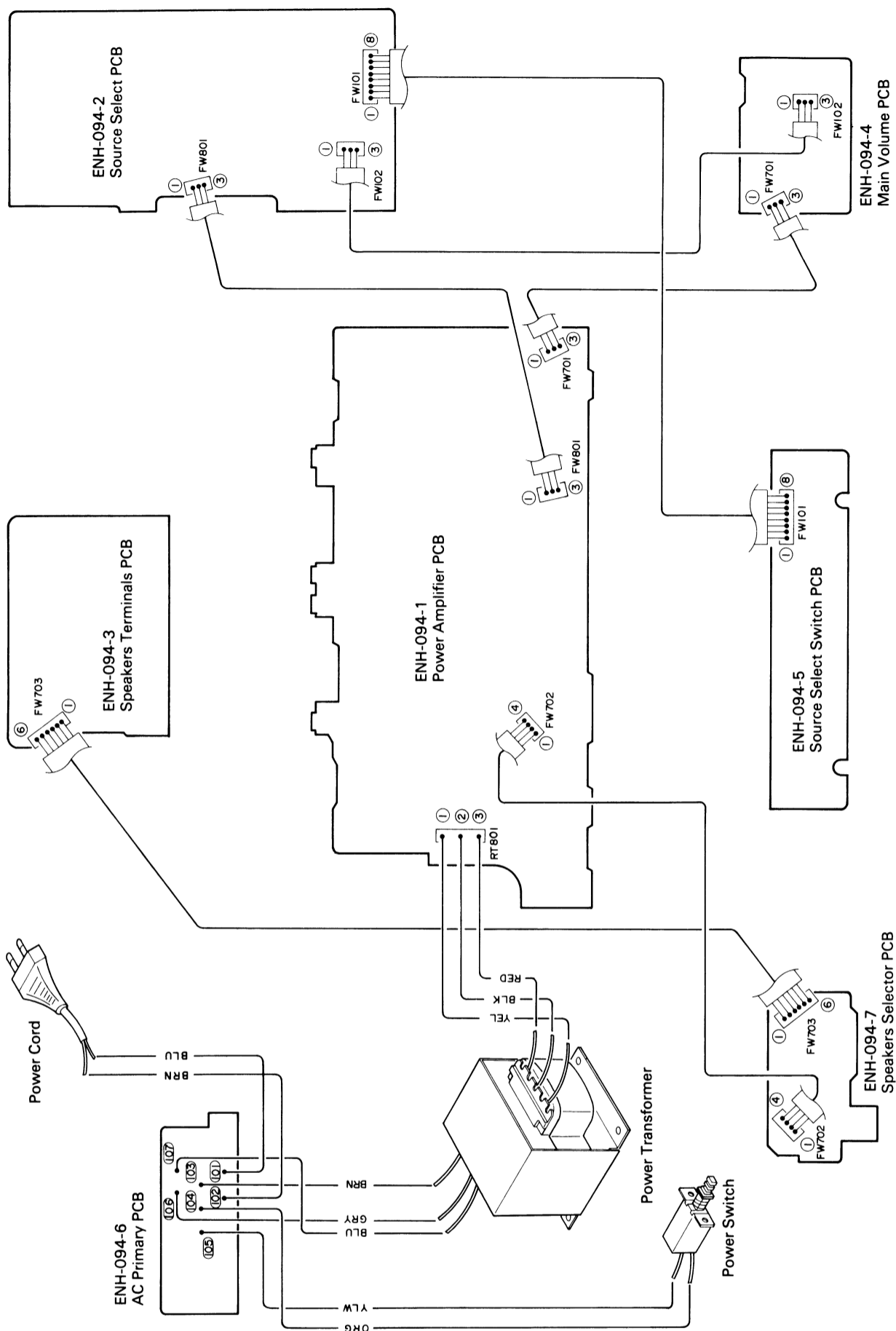
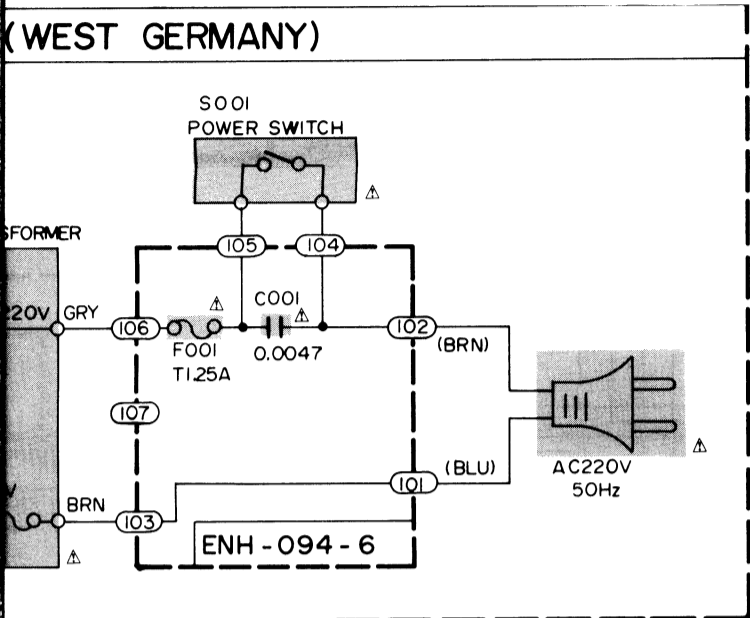

52)

circuited  
al darli-

er point

circuited  
al darli-

e -

# PARTS LIST

## Contents

- Main Parts Locations ..... 2-2
  - Front View ..... 2-2
  - Top View ..... 2-2
  - Rear View ..... 2-2
- Exploded View and Parts Numbers..... 2-3
- Printed Circuit Board Ass'y and Parts List..... 2-5
  - ENH-094 □ Main PC Board Ass'y ..... 2-5
  - TPS-334 □ AC Outlet PC Board Ass'y..... 2-9
- Accessories List..... 2-9
- Packing Materials and Part Numbers..... 2-10

# Main Parts Locations

## ■ Front View

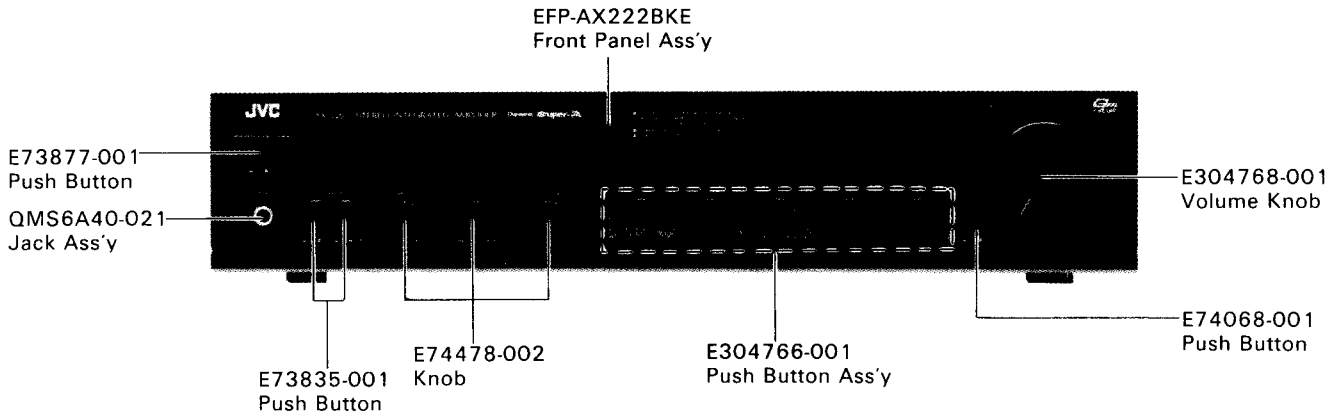

## ■ Top View

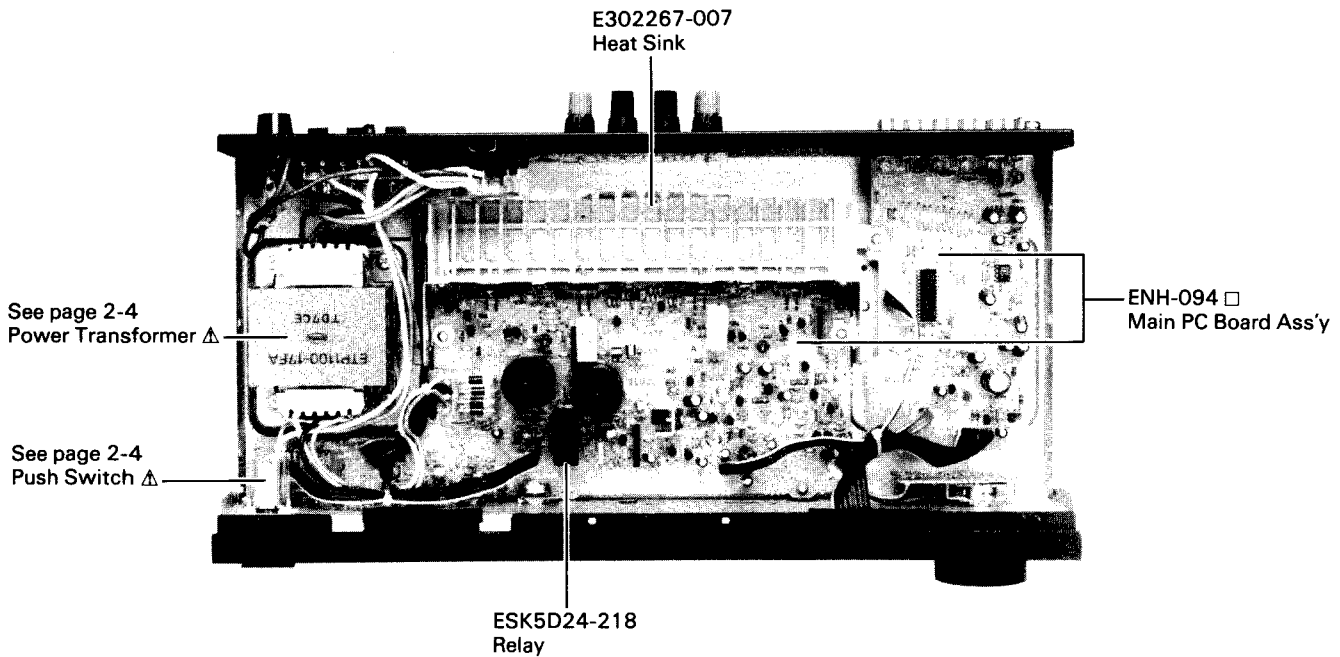

## ■ Rear View

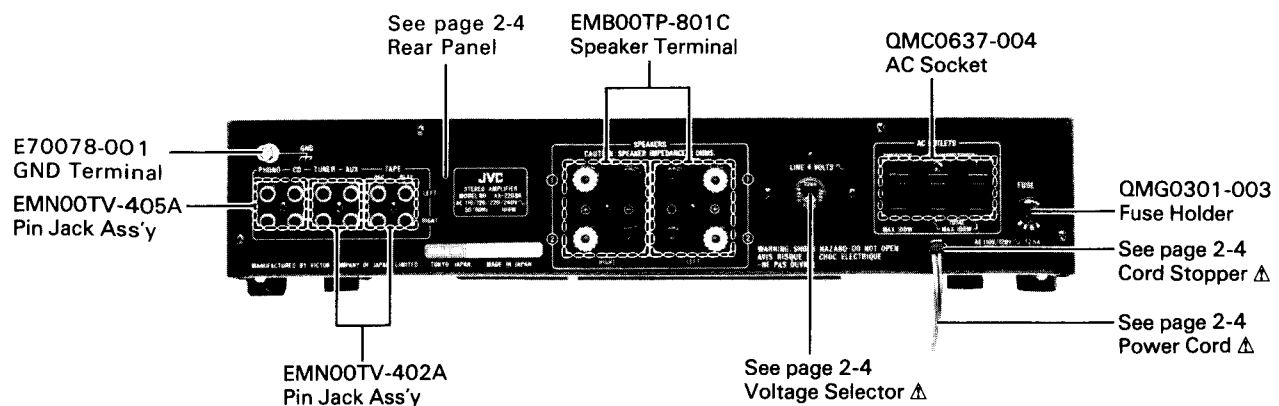

$\Delta$  : Safety Parts



# Exploded View and Part Numbers

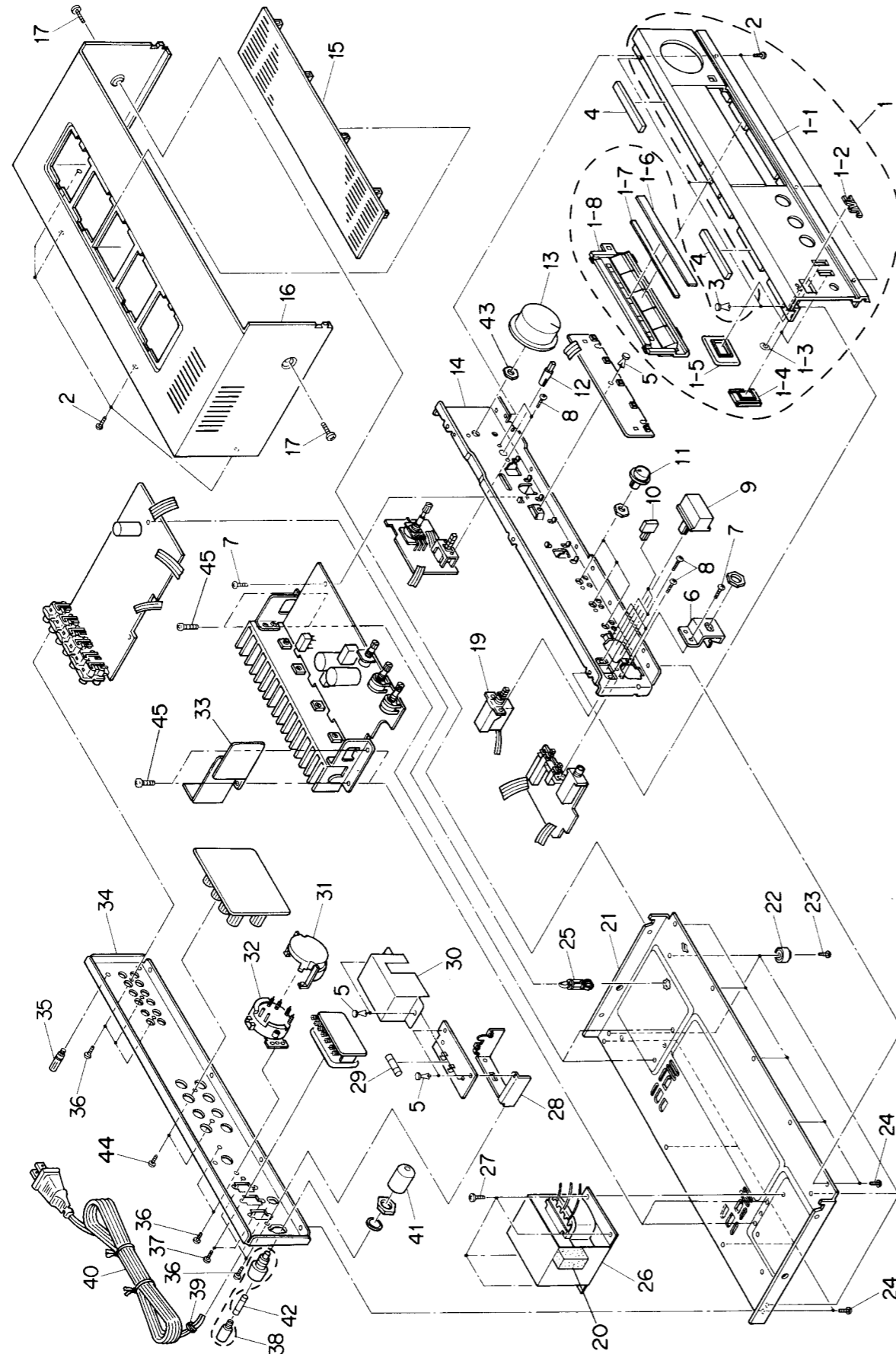

Item	Parts Number	Parts Name	Q'ty	Description	Areas
1	EFP-AX220BKE	Front Panel Ass'y	1		
1-1	E25657-002	Front Panel	1		
1-2	E72968-001	JVC Mark	1		
1-3	E60912-003	Speed Nut	1		
1-4	E73836-001	Push Button Escutcheon	2	SPEAKERS 1,2	
1-5	E73878-002	Push Button Escutcheon	1	POWER	
1-6	E304602-003	IND. Sheet	1		
1-7	E72437-010	Sheet	1		
1-8	E304766-001	Push Button Ass'y	1		
2	SBSB3008M	Screw	7		
3	E48729-009	Prastic Rivet	3		
4	EX0170007N40S02	Felt Spacer	2		Except E.A.G.BS
5	E48729-008	Prastic Rivet	1		E.A.G.BS
	E48729-008	Prastic Rivet	5		
6	E74069-001	Head Phone Bracket	1		
7	SBSB3008CC	Screw	2		
8	SBST3006CC	Screw	6		
9	E73877-001	Push Button	1	POWER	
10	E73835-001	Push Button	2	SPEAKERS 1,2	
11	E74478-002	Knob	3	BASS, TREBLE, BALANCE	
12	E74068-001	Push Button	1	LOUDNESS	
13	E304768-001	Volume Knob	1	VOLUME	
14	E11488-001	Front Bracket	1		
15	E24134-008	Grill	1		E.BS,UE
16	E2561-003	Metal Cover	1		A.G.P,PG,U
17	E25661-004	Metal Cover	1		E.BS,UE
19	E61660-004	Special Screw	2	POWER	
	QSP1106-004	Push Switch	1	POWER	Except BS
	QSP1106-004BS	Push Switch	1	POWER	BS
20	E3400-385	Felt Spacer	1		G
21	E11489-002	Chassis Base	1		
22	E47227-012	Foot	4		
23	SBSB3010Z	Screw	4		
24	SBSB3008N	Screw	9		
25	E44928-003	Fastener	1		
26	ETP1100-17EA	Power Transformer	1		E,A,G
	ETP1100-17EABS	Power Transformer	1		BS
	ETP1100-17FA	Power Transformer	1		P,PG,U
	ETP1100-17UA	Power Transformer	1		UE
	ETP1100-17XA	Power Transformer	1		G
27	E65389-002	Special Screw	4		
28	E304756-001	Circuit Board Bracket	1		E,A,G,BS
29	QMF51A2-1R25S	Fuse	1	FOO1	E,A,G
	QMF51E2-1R25SBS	Fuse	1	FOO1	BS
30	E74093-002	Protect Cover	1		E,A,G,BS
31	E302764-001	Cover	1		P,PG,UE,U
32	QSR0085-008U	Voltage Selector	1		P,PG,U
	QSR0085-011	Voltage Selector	1		UE
33	E304787-002	Protect Cover	1		
34	E25659-006	Rear Panel	1		P,PG,U
	E25659-007	Rear Panel	1		E,A,G,BS
	E25659-008	Rear Panel	1		UE
35	E70078-001	GND Terminal	1		
36	E73273-001	Screw	5		
37	SDSB3008M	Screw	2		P,PG,UE,U
38	QMG0301-003	Fuse Holder	1		P,PG,UE,U
39	QHS3876-162	Cord Stopper	1		Except BS
	QHS3876-162BS	Cord Stopper	1		BS
40	QMP2560-244	Power Cord	1		A
	QMP3900-200	Power Cord	1		E,G
	QMP7600-200	Power Cord	1		P,PG,U
	QMP9017-008BS	Power Cord	1		BS
	QMP7520-200	Power Cord	1		UE
41	E69291-001	Fuse Cover	1		P,PG,UE,U
42	QMF51A2-1R25S	Fuse	1	FOO1	PG,UE,U
	QMF51A2-2R5S	Fuse	1	FOO1	P
43	E71862-001	Volume Nut	1	POWER	
44	SBSB3008MCP	Screw	2		
	E303260-146	Rating Label	1		E,G
45	SBST3006Z	Screw	4		

The Marks for Designated Areas  
 E..... Europe  
 A..... Australia  
 G..... West Germany  
 BS..... U. K.  
 P,PG..... U. S. Military Market  
 UE..... Saudi Arabia  
 U..... Other Countries  
 No mark indicates all areas.

⚠ Safety Parts

# Printed Circuit Board Ass'y and Parts List

## ■ ENH-094 □ Main PC Board Ass'y

Note: ENH-094 □ varies according to the areas employed. See note (1) when placing an order.

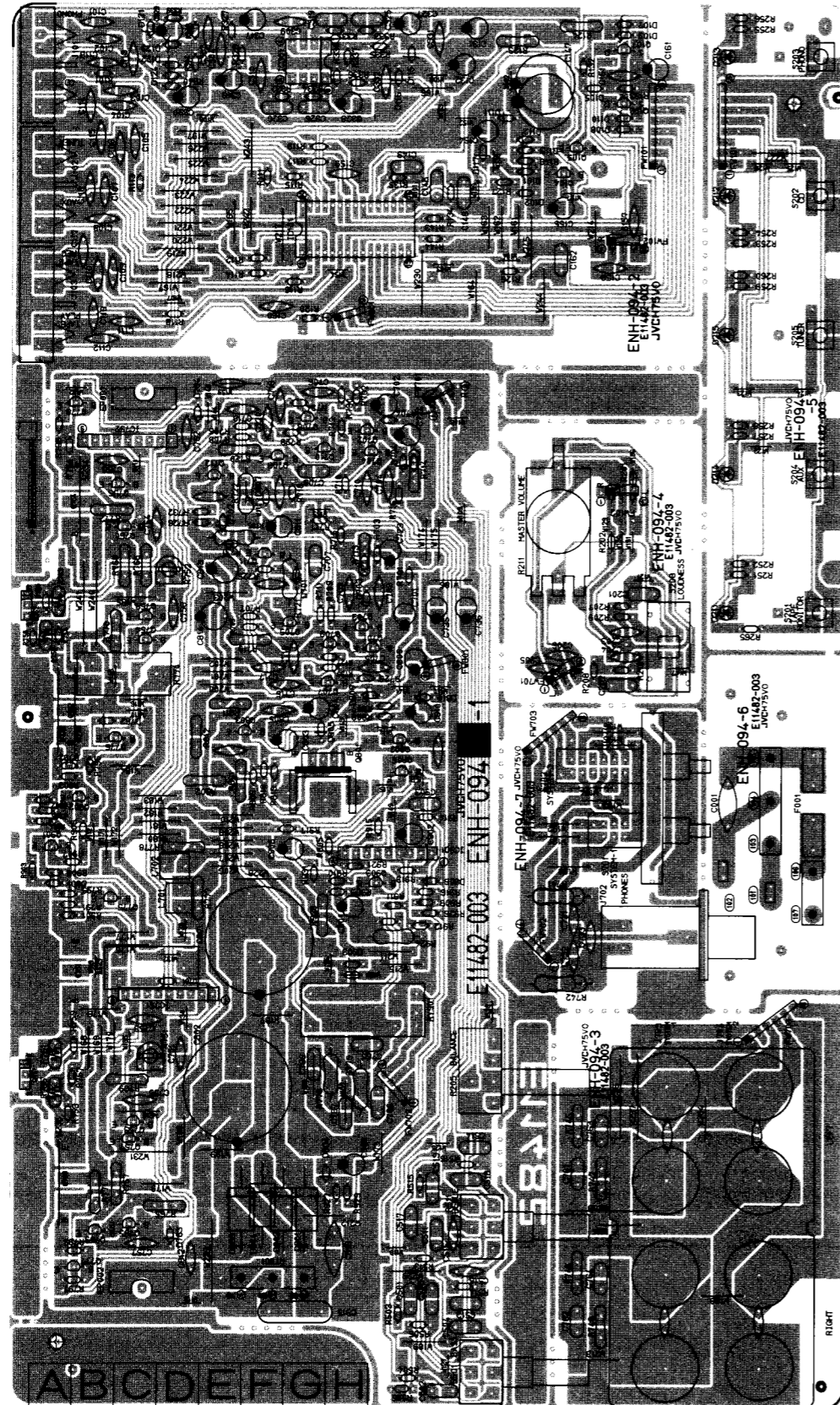

Note (1)

PC Board Ass'y	Designated Areas
ENH-094 <b>A</b>	U. S. Military Market & Other Countries
ENH-094 <b>B</b>	Saudi Arabia
ENH-094 <b>C</b>	Europe, Australia
ENH-094 <b>D</b>	West Germany
ENH-094 <b>E</b> BS	U. K.

### TRANSISTORS

ITEM	PART NUMBER	DESCRIPTION	AREA	
			MAKER	
Q104	DTC144EN	SILICON	ROHM	
Q105	DTA144EN	SILICON	ROHM	
Q107	2SK163(L1)	F.E.T	NEC	
Q108	2SK163(L1)	F.E.T	NEC	
Q701	2SC2240(A,B)	SILICON	TOSHIBA	
Q702	2SC2240(A,B)	SILICON	TOSHIBA	
Q703	2SC2240(A,B)	SILICON	TOSHIBA	
Q704	2SC2240(A,B)	SILICON	TOSHIBA	
Q705	2SA970(GR,BL)	SILICON	TOSHIBA	
Q706	2SA970(GR,BL)	SILICON	TOSHIBA	
Q707	2SA970(GR,BL)	SILICON	TOSHIBA	
Q708	2SA970(GR,BL)	SILICON	TOSHIBA	
Q709	2SA933LN(R,S)	SILICON	ROHM	
Q710	2SA933LN(R,S)	SILICON	ROHM	
Q711	2SC2240(GR,BL)	SILICON	TOSHIBA	
Q712	2SC2240(GR,BL)	SILICON	TOSHIBA	
Q751	2SD636(Q,R)	SILICON	MATSUSHITA	
Q752	2SD636(Q,R)	SILICON	MATSUSHITA	
Q753	2SC2240(GR)	SILICON	TOSHIBA	
Q754	2SC2240(GR)	SILICON	TOSHIBA	
Q755	2SA970(GR)	SILICON	TOSHIBA	
Q756	2SA970(GR)	SILICON	TOSHIBA	
Q757	2SC2235(O,Y)	SILICON	TOSHIBA	
Q758	2SC2235(O,Y)	SILICON	TOSHIBA	
Q759	2SA965(O,Y)	SILICON	TOSHIBA	
Q760	2SA965(O,Y)	SILICON	TOSHIBA	
Q761	2SD716LB(O,R)	SILICON	TOSHIBA	
Q762	2SD716LB(O,R)	SILICON	TOSHIBA	
Q763	2SB686LB(O,R)	SILICON	TOSHIBA	
Q764	2SB686LB(O,R)	SILICON	TOSHIBA	
Q775	2SC1740(R,S)	SILICON	ROHM	
Q776	2SC1740(R,S)	SILICON	ROHM	
Q777	2SA933(R,S)	SILICON	ROHM	
Q778	2SA933(R,S)	SILICON	ROHM	
Q801	2SD1913(R,S)	SILICON	SANYO	
Q802	2SA965(O,Y)	SILICON	TOSHIBA	
Q803	2SA933(R,S)	SILICON	ROHM	
Q805	2SC1740(R,S)	SILICON	ROHM	
Q901	2SC2240(GR,BL)	SILICON	TOSHIBA	
Q902	2SC2240(GR,BL)	SILICON	TOSHIBA	
Q903	2SA970(GR,BL)	SILICON	TOSHIBA	

### I. C. S

ITEM	PART NUMBER	DESCRIPTION	AREA	
			MAKER	
IC101	LC7818	I.C.	SANYO	
IC301	NJM4560DD	I.C.	JRC	
IC751	VC5022(X,Y)	I.C.	ROHM	
IC752	VC5022(X,Y)	I.C.	ROHM	
IC901	TA7317P	I.C.	TOSHIBA	

### DIODES

ITEM	PART NUMBER	DESCRIPTION	AREA	
			MAKER	
D101	1SS133	SILICON	ROHM	
D102	1SS133	SILICON	ROHM	
D105	1SS133	SILICON	ROHM	
D111	1SS133	SILICON	ROHM	
D112	1SS133	SILICON	ROHM	
D113	MTZ5.6JC	ZENER	ROHM	
D115	MTZ13JC	ZENER	ROHM	
D116	MTZ13JC	ZENER	ROHM	
D117	MTZ6.8JC	ZENER	ROHM	
D121	MTZ13JC	ZENER	ROHM	
D122	MTZ13JC	ZENER	ROHM	
D123	MTZ13JC	ZENER	ROHM	
D124	MTZ13JC	ZENER	ROHM	
D211	SLR-34VR3F	L.E.D.	ROHM	
D212	SLR-34DU3F	L.E.D.	ROHM	
D213	SLR-34DU3F	L.E.D.	ROHM	
D214	SLR-34DU3F	L.E.D.	ROHM	
D215	SLR-34DU3F	L.E.D.	ROHM	
D701	1SS133	SILICON	ROHM	
D702	1SS133	SILICON	ROHM	
D703	1SS133	SILICON	ROHM	
D704	1SS133	SILICON	ROHM	
D761	1SS133	SILICON	ROHM	
D762	1SS133	SILICON	ROHM	
D763	1SS133	SILICON	ROHM	
D764	1SS133	SILICON	ROHM	
△ D801	30DL2FC	SILICON	NIHONINTER	
△ D802	30DL2FC	SILICON	NIHONINTER	
△ D803	30DL2FC	SILICON	NIHONINTER	
△ D804	30DL2FC	SILICON	NIHONINTER	
D805	MTZ15JC	ZENER	ROHM	
D806	1SS133	SILICON	ROHM	
D807	MTZ18JC	ZENER	ROHM	
D809	MTZ16JC	ZENER	ROHM	
D810	MTZ16JC	ZENER	ROHM	
D901	1SS133	SILICON	ROHM	
D902	1SS133	SILICON	ROHM	
D903	1SS133	SILICON	ROHM	
D904	1SS133	SILICON	ROHM	

### CAPACITORS

ITEM	PART NUMBER	DESCRIPTION	AREA	
			MAKER	
△ C001	QCZ9019-472	4700PF 250V CERAMIC		C
△ C001	QCZ9019-472	4700PF 250V CERAMIC		D
△ C001	QCZ9019-472BS	4700PF 250V CERAMIC		EBS
C101	QCS21HJ-101	100PF 50V CERAMIC		A
C101	QCS21HJ-101	100PF 50V CERAMIC		B
C101	QCS21HJ-101	100PF 50V CERAMIC		C
C101	QCS21HJ-101	100PF 50V CERAMIC		EBS
C101	QCS21HJ-221	220PF 50V CERAMIC		D
C102	QCS21HJ-101	100PF 50V CERAMIC		A
C102	QCS21HJ-101	100PF 50V CERAMIC		B
C102	QCS21HJ-101	100PF 50V CERAMIC		C
C102	QCS21HJ-101	100PF 50V CERAMIC		EBS
C102	QCS21HJ-221	220PF 50V CERAMIC		D
C103	QCS21HJ-221	220PF 50V CERAMIC		D
C104	QCS21HJ-221	220PF 50V CERAMIC		D
C105	QCS21HJ-221	220PF 50V CERAMIC		D
C106	QCS21HJ-221	220PF 50V CERAMIC		D
C107	QCS21HJ-221	220PF 50V CERAMIC		D
C108	QCS21HJ-221	220PF 50V CERAMIC		D
C109	QCS21HJ-331	330PF 50V CERAMIC		D
C110	QCS21HJ-331	330PF 50V CERAMIC		D
C111	QCS21HJ-221	220PF 50V CERAMIC		D
C112	QCS21HJ-221	220PF 50V CERAMIC		D
C113	QCF21HP-473	0.47MF 50V CERAMIC		
C114	QCF21HP-223	0.022MF 50V CERAMIC		
C115	QCF21HP-223	0.022MF 50V CERAMIC		
C116	QCF21HP-223	0.022MF 50V CERAMIC		
C117	QCF21HP-223	0.022MF 50V CERAMIC		
C118	QCF21HP-473	0.47MF 50V CERAMIC		
C131	QETB1EM-107	100MF 25V ELECTRO		
C132	QETB1EM-107	100MF 25V ELECTRO		
C146	QFN81HJ-562	5600PF 50V MYLAR		
C147	QETB0JM-228	2200MF 6.3V ELECTRO		
C148	QFN81HJ-562	5600PF 50V MYLAR		
C149	QFN81HK-473	0.47MF 50V MYLAR		
C151	QCS21HJ-331	330PF 50V CERAMIC		
C154	QETB1CM-107	100MF 16V ELECTRO		
C155	QETB1HM-474	0.47MF 50V ELECTRO		
C161	QEN51HM-105	1MF 50V NON POLE		
C162	QFN81HK-103	0.01MF 50V MYLAR		
C201	QFN81HK-333	0.033MF 50V MYLAR		
C202	QFN81HK-333	0.033MF 50V MYLAR		
C203	QCS21HJ-181	180PF 50V CERAMIC		
C204	QCS21HJ-181	180PF 50V CERAMIC		
C205	QCS21HJ-470	47PF 50V CERAMIC		

△ : SAFETY PARTS

CAPACITORS

ITEM	PART NUMBER	DESCRIPTION	AREA
C206	QCS21HJ-470	47PF 50V CERAMIC	D
C303	QCS21HJ-101	100PF 50V CERAMIC	A
C303	QCS21HJ-101	100PF 50V CERAMIC	B
C303	QCS21HJ-101	100PF 50V CERAMIC	C
C303	QCS21HJ-101	100PF 50V CERAMIC	EBS
C303	QCS21HJ-331	330PF 50V CERAMIC	D
C304	QCS21HJ-101	100PF 50V CERAMIC	A
C304	QCS21HJ-101	100PF 50V CERAMIC	B
C304	QCS21HJ-101	100PF 50V CERAMIC	C
C304	QCS21HJ-101	100PF 50V CERAMIC	EBS
C304	QCS21HJ-331	330PF 50V CERAMIC	D
C309	QCS21HJ-101	100PF 50V CERAMIC	
C310	QCS21HJ-101	100PF 50V CERAMIC	
C317	QETB1AM-107	100MF 10V ELECTRO	
C318	QETB1AM-107	100MF 10V ELECTRO	
C319	QFN81HK-182	1800PF 50V MYLAR	
C320	QFN81HK-182	1800PF 50V MYLAR	
C325	QFN81HK-682	6800PF 50V MYLAR	
C326	QFN81HK-682	6800PF 50V MYLAR	
C327	EETB2AM-106E	10MF 100V ELECTRO	
C328	EETB2AM-106E	10MF 100V ELECTRO	
C329	EEZ1601-226	22MF 16V ELECTRO	
C330	EEZ1601-226	22MF 16V ELECTRO	
C501	QFN81HK-153	0.015MF 50V MYLAR	
C502	QFN81HK-153	0.015MF 50V MYLAR	
C503	QFN81HK-823	0.082MF 50V MYLAR	
C504	QFN81HK-823	0.082MF 50V MYLAR	
C511	QFN81HK-332	3300PF 50V MYLAR	
C512	QFN81HK-332	3300PF 50V MYLAR	
C513	QFN81HK-183	0.018MF 50V MYLAR	
C514	QFN81HK-183	0.018MF 50V MYLAR	
C515	QCS21HJ-221	220PF 50V CERAMIC	
C516	QCS21HJ-221	220PF 50V CERAMIC	
C517	QFN81HK-122	1200PF 50V MYLAR	
C518	QFN81HK-122	1200PF 50V MYLAR	
C701	EEZ1601-226	22MF 16V ELECTRO	
C702	EEZ1601-226	22MF 16V ELECTRO	
C703	QCS21HJ-470	47PF 50V CERAMIC	
C704	QCS21HJ-470	47PF 50V CERAMIC	
C705	QCS21HJ-101	100PF 50V CERAMIC	A
C705	QCS21HJ-101	100PF 50V CERAMIC	B
C705	QCS21HJ-101	100PF 50V CERAMIC	C
C705	QCS21HJ-101	100PF 50V CERAMIC	EBS
C705	QCS21HJ-470	47PF 50V CERAMIC	D
C706	QCS21HJ-101	100PF 50V CERAMIC	A
C706	QCS21HJ-101	100PF 50V CERAMIC	B
C706	QCS21HJ-101	100PF 50V CERAMIC	C
C706	QCS21HJ-101	100PF 50V CERAMIC	EBS
C706	QCS21HJ-470	47PF 50V CERAMIC	D
C707	QFN81HK-332	3300PF 50V MYLAR	
C708	QFN81HK-332	3300PF 50V MYLAR	
C709	QCS21HJ-100	10PF 50V CERAMIC	
C710	QCS21HJ-100	10PF 50V CERAMIC	
C715	QCS21HJ-330	33PF 50V CERAMIC	
C716	QCS21HJ-330	33PF 50V CERAMIC	
C717	QCS21HJ-330	33PF 50V CERAMIC	
C718	QCS21HJ-330	33PF 50V CERAMIC	
C719	QCS21HJ-220	22PF 50V CERAMIC	
C720	QCS21HJ-220	22PF 50V CERAMIC	
C723	QETB1CM-476	47MF 16V ELECTRO	
C724	QETB1CM-476	47MF 16V ELECTRO	
C731	QCS21HJ-101	100PF 50V CERAMIC	D
C732	QCS21HJ-101	100PF 50V CERAMIC	D
C733	QCS21HJ-101	100PF 50V CERAMIC	D
C735	QETB1HM-105	1MF 50V ELECTRO	
C736	QETB1HM-105	1MF 50V ELECTRO	
C751	QCF21HP-103	0.01MF 50V CERAMIC	
C752	QCF21HP-103	0.01MF 50V CERAMIC	
C753	QCF21HP-103	0.01MF 50V CERAMIC	
C754	QCF21HP-103	0.01MF 50V CERAMIC	
C755	QCS21HJ-470	47PF 50V CERAMIC	
C756	QCS21HJ-470	47PF 50V CERAMIC	
C757	QCS21HJ-470	47PF 50V CERAMIC	
C758	QCS21HJ-470	47PF 50V CERAMIC	
C761	QFN81HK-103	0.01MF 50V MYLAR	D
C762	QFN81HK-103	0.01MF 50V MYLAR	D
C763	QFN81HK-103	0.01MF 50V MYLAR	D
C764	QFN81HK-103	0.01MF 50V MYLAR	D
C765	QFN81HK-104	0.1MF 50V MYLAR	B
C765	QFN81HK-104	0.1MF 50V MYLAR	C
C765	QFN81HK-104	0.1MF 50V MYLAR	D
C765	QFN81HK-104	0.1MF 50V MYLAR	EBS
C765	QFN81HK-473	0.047MF 50V MYLAR	A
C766	QFN81HK-104	0.1MF 50V MYLAR	B
C766	QFN81HK-104	0.1MF 50V MYLAR	C
C766	QFN81HK-104	0.1MF 50V MYLAR	D
C766	QFN81HK-104	0.1MF 50V MYLAR	EBS
C766	QFN81HK-473	0.047MF 50V MYLAR	A
C767	QFN81HK-104	0.1MF 50V MYLAR	B
C767	QFN81HK-104	0.1MF 50V MYLAR	C
C767	QFN81HK-104	0.1MF 50V MYLAR	D
C767	QFN81HK-104	0.1MF 50V MYLAR	EBS
C768	QFN81HK-104	0.1MF 50V MYLAR	B
C768	QFN81HK-104	0.1MF 50V MYLAR	C
C768	QFN81HK-104	0.1MF 50V MYLAR	D

CAPACITORS

ITEM	PART NUMBER	DESCRIPTION	AREA
C768	QFN81HK-104	0.1MF 50V MYLAR	EBS
C801	QEZ0086-688E	6800MF 50V NON POLE	
C802	QEZ0086-688E	6800MF 50V NON POLE	
C803	QEHC1HM-476	47MF 50V ELECTRO	
C804	QETB1HM-476	47MF 50V ELECTRO	
C805	QCS21HJ-101	100PF 50V CERAMIC	
C809	QETB1EM-476	47MF 25V ELECTRO	
C810	QETB1EM-476	47MF 25V ELECTRO	
C811	QETB1EM-106	10MF 25V ELECTRO	
C812	QCS21HJ-821	820PF 50V CERAMIC	D
C813	QETB1HM-476	47MF 50V ELECTRO	
C814	QETB1HM-476	47MF 50V ELECTRO	
C816	QCE22HP-103A	0.01MF 500V CERAMIC	
C901	QETB1HM-226	22MF 50V ELECTRO	
C902	QETB1AM-107	100MF 10V ELECTRO	
C903	QFN81HK-102	1000PF 50V MYLAR	
C906	QETB1HM-226	22MF 50V ELECTRO	
C908	QETB1HM-105	1MF 50V ELECTRO	

RESISTORS

ITEM	PART NUMBER	DESCRIPTION	AREA
R101	QRD167J-4R7	4.7 1/6W CARBON	
R111	QRD167J-331	330 1/6W CARBON	
R112	QRD167J-331	330 1/6W CARBON	
R113	QRD167J-331	330 1/6W CARBON	
R114	QRD167J-331	330 1/6W CARBON	
R115	QRD167J-331	330 1/6W CARBON	
R116	QRD167J-331	330 1/6W CARBON	
R117	QRD167J-331	330 1/6W CARBON	
R118	QRD167J-331	330 1/6W CARBON	
R119	QRD167J-331	330 1/6W CARBON	
R120	QRD167J-331	330 1/6W CARBON	
R123	QRZ0077-101	100 1/4W FUSIBLE	
R124	QRZ0077-101	100 1/4W FUSIBLE	
R126	QRD167J-104	100K 1/6W CARBON	
R127	QRD167J-104	100K 1/6W CARBON	
R132	QRD167J-103	10K 1/6W CARBON	
R133	QRD167J-105	1M 1/6W CARBON	
R134	QRD167J-103	10K 1/6W CARBON	
R135	QRD167J-474	470K 1/6W CARBON	
R143	QRD167J-681	680 1/6W CARBON	
R144	QRD167J-681	680 1/6W CARBON	
R146	QRD167J-122	1.2K 1/6W CARBON	
R205	QVDA98W-EF5B	250K VARIABLE	
R207	QRD167J-223	22K 1/6W CARBON	
R208	QRD167J-223	22K 1/6W CARBON	
R209	QRD167J-105	1M 1/6W CARBON	
R210	QRD167J-105	1M 1/6W CARBON	
R211	QVN9A3B-5F5V	250K VARIABLE	
R251	QRD167J-122	1.2K 1/6W CARBON	
R252	QRD167J-122	1.2K 1/6W CARBON	
R253	QRD167J-122	1.2K 1/6W CARBON	
R254	QRD167J-122	1.2K 1/6W CARBON	
R255	QRD167J-122	1.2K 1/6W CARBON	
R256	QRD167J-122	1.2K 1/6W CARBON	
R257	QRD167J-122	1.2K 1/6W CARBON	
R258	QRD167J-122	1.2K 1/6W CARBON	
R259	QRD167J-122	1.2K 1/6W CARBON	
R260	QRD167J-122	1.2K 1/6W CARBON	
R265	QRD167J-104	100K 1/6W CARBON	
R303	QRD167J-473	47K 1/6W CARBON	
R304	QRD167J-473	47K 1/6W CARBON	
R327	QRD167J-821	820 1/6W CARBON	
R328	QRD167J-821	820 1/6W CARBON	
R331	QRD167J-393	39K 1/6W CARBON	
R332	QRD167J-393	39K 1/6W CARBON	
R333	QRD167J-474	470K 1/6W CARBON	
R334	QRD167J-474	470K 1/6W CARBON	
R335	QRD167J-471	470 1/6W CARBON	
R336	QRD167J-471	470 1/6W CARBON	
R337	QRD167J-104	100K 1/6W CARBON	
R338	QRD167J-104	100K 1/6W CARBON	
R339	QRD167J-222	2.2K 1/6W CARBON	
R340	QRD167J-222	2.2K 1/6W CARBON	
R501	QVDB98C-E15B	100K VARIABLE	
R503	QRD167J-203	20K 1/6W CARBON	
R504	QRD167J-203	20K 1/6W CARBON	
R505	QRD167J-362	3.6K 1/6W CARBON	
R506	QRD167J-362	3.6K 1/6W CARBON	
R511	QVDB98C-E15B	100K VARIABLE	
R513	QRD167J-472	4.7K 1/6W CARBON	
R514	QRD167J-472	4.7K 1/6W CARBON	
R515	QRD167J-821	820 1/6W CARBON	
R516	QRD167J-821	820 1/6W CARBON	
R701	QRD167J-102	1K 1/6W CARBON	
R702	QRD167J-102	1K 1/6W CARBON	
R703	QRD167J-104	100K 1/6W CARBON	
R704	QRD167J-104	100K 1/6W CARBON	
R705	QRD167J-222	2.2K 1/6W CARBON	
R706	QRD167J-222	2.2K 1/6W CARBON	
R707	QRD167J-222	2.2K 1/6W CARBON	

Δ : SAFETY PARTS

RESISTORS

ITEM	PART NUMBER	DESCRIPTION	AREA
R708	QRD167J-222	2.2K 1/6W CARBON	
R709	QRD167J-103	10K 1/6W CARBON	
R710	QRD167J-103	10K 1/6W CARBON	
R711	QRD167J-101	100 1/6W CARBON	
R712	QRD167J-101	100 1/6W CARBON	
R713	QRD167J-821	820 1/6W CARBON	
R714	QRD167J-821	820 1/6W CARBON	
R715	QRD167J-163	16K 1/6W CARBON	
R716	QRD167J-163	16K 1/6W CARBON	
R717	QRD167J-823	82K 1/6W CARBON	
R718	QRD167J-823	82K 1/6W CARBON	
R719	QRD14CJ-121S	120 1/4W UNF. CARBON	
R720	QRD14CJ-121S	120 1/4W UNF. CARBON	
R721	QRD125J-822	8.2K 1/2W UNF. CARBON	
R722	QRD125J-822	8.2K 1/2W UNF. CARBON	
R725	QRD167J-391	390 1/6W CARBON	
R726	QRD167J-391	390 1/6W CARBON	
R727	QRD167J-152	1.5K 1/6W CARBON	
R728	QRD167J-152	1.5K 1/6W CARBON	
R729	QRD167J-333	33K 1/6W CARBON	
R730	QRD167J-333	33K 1/6W CARBON	
R731	QRD167J-391	390 1/6W CARBON	
R732	QRD167J-391	390 1/6W CARBON	
R733	QRD167J-152	1.5K 1/6W CARBON	
R734	QRD167J-152	1.5K 1/6W CARBON	
R735	QRG012J-332A	3.3K 1W D.M.FILM	
R741	QRG022J-331A	330 2W D.M.FILM	
R742	QRG022J-331A	330 2W D.M.FILM	
R745	QRD14CJ-100S	10 1/4W UNF. CARBON	D
R746	QRD14CJ-100S	10 1/4W UNF. CARBON	D
R747	QRD14CJ-100S	10 1/4W UNF. CARBON	D
R748	QRD14CJ-100S	10 1/4W UNF. CARBON	D
R751	QVZ3518-471	470 0.1W VARIABLE	
R752	QVZ3518-471	470 0.1W VARIABLE	
R753	QRD167J-101	100 1/6W CARBON	
R754	QRD167J-101	100 1/6W CARBON	
R755	ERT-D2WFL351S	350 1/4W THERMISTOR	
R756	ERT-D2WFL351S	350 1/4W THERMISTOR	
R757	QRD167J-471	470 1/6W CARBON	
R758	QRD167J-471	470 1/6W CARBON	
R759	QRD167J-391	390 1/6W CARBON	
R760	QRD167J-391	390 1/6W CARBON	
R761	ERT-D2WHL202S	2K 1/4W THRMISTOR	
R762	ERT-D2WHL202S	2K 1/4W THRMISTOR	
R765	QRZ0077-272	2.7K 1/4W FUSIBLE	
R766	QRZ0077-272	2.7K 1/4W FUSIBLE	
R767	QRZ0077-471	470 1/4W FUSIBLE	
R768	QRZ0077-471	470 1/4W FUSIBLE	
R769	QRZ0077-100	10 1/4W FUSIBLE	
R770	QRZ0077-100	10 1/4W FUSIBLE	
R771	QRZ0077-100	10 1/4W FUSIBLE	
R772	QRZ0077-100	10 1/4W FUSIBLE	
R773	ERF032K-R22	0.22 3W CEMENT	
R774	ERF032K-R22	0.22 3W CEMENT	
R775	QRG012J-100A	10 1W D.M.FILM	
R776	QRG012J-100A	10 1W D.M.FILM	
R777	QRD14CJ-330S	33 1/4W UNF. CARBON	
R778	QRD14CJ-330S	33 1/4W UNF. CARBON	
R791	QRD167J-391	390 1/6W CARBON	
R792	QRD167J-391	390 1/6W CARBON	
R793	QRD167J-391	390 1/6W CARBON	
R794	QRD167J-391	390 1/6W CARBON	
R795	QRD167J-331	330 1/6W CARBON	
R796	QRD167J-331	330 1/6W CARBON	
R797	QRD167J-331	330 1/6W CARBON	
R798	QRD167J-331	330 1/6W CARBON	
R801	QRZ0077-330	33 1/4W FUSIBLE	
R802	QRZ0077-330	33 1/4W FUSIBLE	
R805	QRD167J-823	82K 1/6W CARBON	
R806	QRD167J-331	330 1/6W CARBON	
R807	QRD167J-223	22K 1/6W CARBON	
R808	QRD167J-203	20K 1/6W CARBON	
R809	QRD167J-563	56K 1/6W CARBON	
R810	QRD167J-163	16K 1/6W CARBON	
R811	QRZ0077-330	33 1/4W FUSIBLE	
R812	QRZ0077-330	33 1/4W FUSIBLE	
R813	QRD167J-103	10K 1/6W CARBON	
R901	QRD167J-272	2.7K 1/6W CARBON	
R902	QRD167J-272	2.7K 1/6W CARBON	
R903	QRD167J-183	18K 1/6W CARBON	
R904	QRD167J-183	18K 1/6W CARBON	
R905	QRD167J-473	47K 1/6W CARBON	
R906	QRD167J-473	47K 1/6W CARBON	
R907	QRD167J-223	22K 1/6W CARBON	
R908	QRD167J-223	22K 1/6W CARBON	
R909	QRD167J-332	3.3K 1/6W CARBON	
R910	QRD167J-103	10K 1/6W CARBON	
R911	QRD167J-104	100K 1/6W CARBON	
R912	QRD167J-823	82K 1/6W CARBON	
R913	QRD167J-473	47K 1/6W CARBON	

RESISTORS

ITEM	PART NUMBER	DESCRIPTION	AREA
R914	QRD167J-104	100K 1/6W CARBON	
R915	QRD167J-683	68K 1/6W CARBON	
R916	QRD167J-563	56K 1/6W CARBON	
R917	QRD167J-163	16K 1/6W CARBON	
R921	QRD167J-224	220K 1/6W CARBON	
R924	QRG022J-821A	820 2W O.M.FILM	
R925	QRD14CJ-470S	47 1/4W UNF. CARBON	
R926	QRD167J-153	15K 1/6W CARBON	
R927	QRD167J-472	4.7K 1/6W CARBON	
R929	QRD167J-562	5.6K 1/6W CARBON	
R931	QRD167J-223	22K 1/6W CARBON	

OTHERS

ITEM	PART NUMBER	DESCRIPTION	AREA
	EMG7331-001	FUSE CLIP	C
	EMG7331-001	FUSE CLIP	D
	EMG7331-001	FUSE CLIP	EBS
	E11482-003	CIRCUIT BOARD	A
	E11482-003	CIRCUIT BOARD	B
	E11482-003	CIRCUIT BOARD	C
	E11482-003	CIRCUIT BOARD	D
	E11482-003BS	CIRCUIT BOARD	EBS
	E302267-007	HEAT SINK	
	E304769-001	H.S. BRACKET(L)	
	E304769-002	H.S. BRACKET(R)	
	E65508-002	TAB	C
	E65508-002	TAB	D
	E65508-002	TAB	EBS
	E67132-T1R25	FUSE LABEL	C
	E67132-T1R25	FUSE LABEL	D
	E67132-T1R25	FUSE LABEL	EBS
	E67764-202	WRAPPING TERMINAL	C
	E67764-202	WRAPPING TERMINAL	D
	E67764-202	WRAPPING TERMINAL	EBS
	E67764-203	WRAPPING TERMINAL	C
	E67764-203	WRAPPING TERMINAL	D
	E67764-203	WRAPPING TERMINAL	EBS
	E70306-001	HEAT SINK	
	E73265-001	SCREW	
	SBSB3008CC	SCREW	
	SBSB3008CC	SCREW	
	SBSE3012CC	SCREW	
J101	EMN00TV-405A	4P PIN JACK	
J102	EMN00TV-402A	4P PIN JACK	
J103	EMN00TV-402A	4P PIN JACK	
J702	QMS640-021	HEADPHONE JACK	
J703	EMB00TP-801C	SPEAKER TERMINAL	
J704	EMB00TP-801C	SPEAKER TERMINAL	
L701	EQL0001-R45	INDUCTOR	
L702	EQL0001-R45	INDUCTOR	
S201	ESP0001-007	TACT SWITCH	
S202	ESP0001-007	TACT SWITCH	
S203	ESP0001-007	TACT SWITCH	
S204	ESP0001-007	TACT SWITCH	
S205	ESP0001-007	TACT SWITCH	
S208	QSTL101-E01	PUSH SWITCH	
S701	QST9241-E01	PUSH SWITCH	
S702	QST9241-E01	PUSH SWITCH	
EP001	E70859-001	EARTH PLATE	
EP002	E70859-001	EARTH PLATE	D
FW101	EWR38B-20SST	FLAT WIRE	
FW102	EWR23C-16NN	FLAT WIRE	
FW701	EWR23C-13NN	FLAT WIRE	
FW702	EWR34B-20SST	FLAT WIRE	
FW703	EWR36B-25SST	FLAT WIRE	
FW801	EWR33B-20SST	FLAT WIRE	
RT801	E67764-103	WRAPPING TERMINAL	
RY901	ESK5D24-218	RELAY	

△ : SAFETY PARTS

■ TPS-334 □ AC Outlet PC Board Ass'y

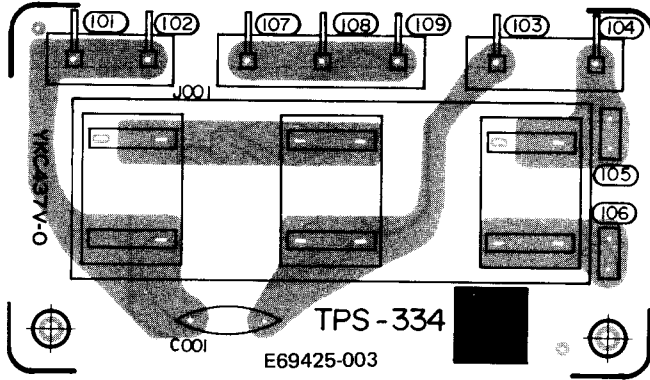

Note (1)

PC Board Ass'y	Designated Areas
TPS-334 [A]	U. S. Military Market & Other Countries
TPS-334 [B]	Saudi Arabia

CAPACITORS

△ ITEM	PART NUMBER	DESCRIPTION	AREA
△ C001	QCZ9018-103	0.01MF 250V CERAMIC	A
△ C001	QCZ9038-103	0.01MF 250V CERAMIC	B

OTHERS

△ ITEM	PART NUMBER	DESCRIPTION	AREA
	E65508-002	TAB	
	E67764-302	WRAPPING TERMINAL	
	E67764-402	WRAPPING TERMINAL	
	E67764-403	WRAPPING TERMINAL	
	E69425-003	CIRCUIT BOARD	
△	QMC0637-004	AC OUTLET	

△ : SAFETY PARTS

Accessories List

△	Part Number	Part Name	Q'ty	Description	Areas
	E30580-1431B E30580-1431BS BT20029C BT20098 BT20046C	Instruction Book Instruction Book Warranty Card Warranty Card Service Information Card	1 1 1 1 1	for Australia for New Zealand	Except BS BS A A P, PG
	BT20048B BT20060 BT20066 BT20064 QZL1008-001	Warranty Card Warranty Card EEC Agency Warranty Card FTZ Information Sheet	1 1 1 1 1		P, PG BS G, BS G G
△ △ △ △	E04056 QMF51A2-1R25S QMF51A2-2R5S QMF51A2-2R0S E67142-T1R25	Siemens Plug Fuse Fuse Fuse Fuse Label	1 1 1 1 1		PG, U, UE P PG, U UE P
	E67142-T2R5 E67142-T2R0 E6581-4 E41202-2 E41202-2B	Fuse Label Fuse Label Envelope Envelope Envelope	1 1 1 1 1	for Fuse & Fuse Label for Instruction Book for Instruction Book	PG, U UE P, PG, UE, U Except BS BS

△: Safety Parts

E.....Europe  
A.....Australia  
G.....West Germany  
BS.....U. K.  
P, PG.....U. S. Military Market  
UE.....Saudi Arabia  
U.....Other Countries

No mark indicates all areas.

## Packing Materials and Part Numbers

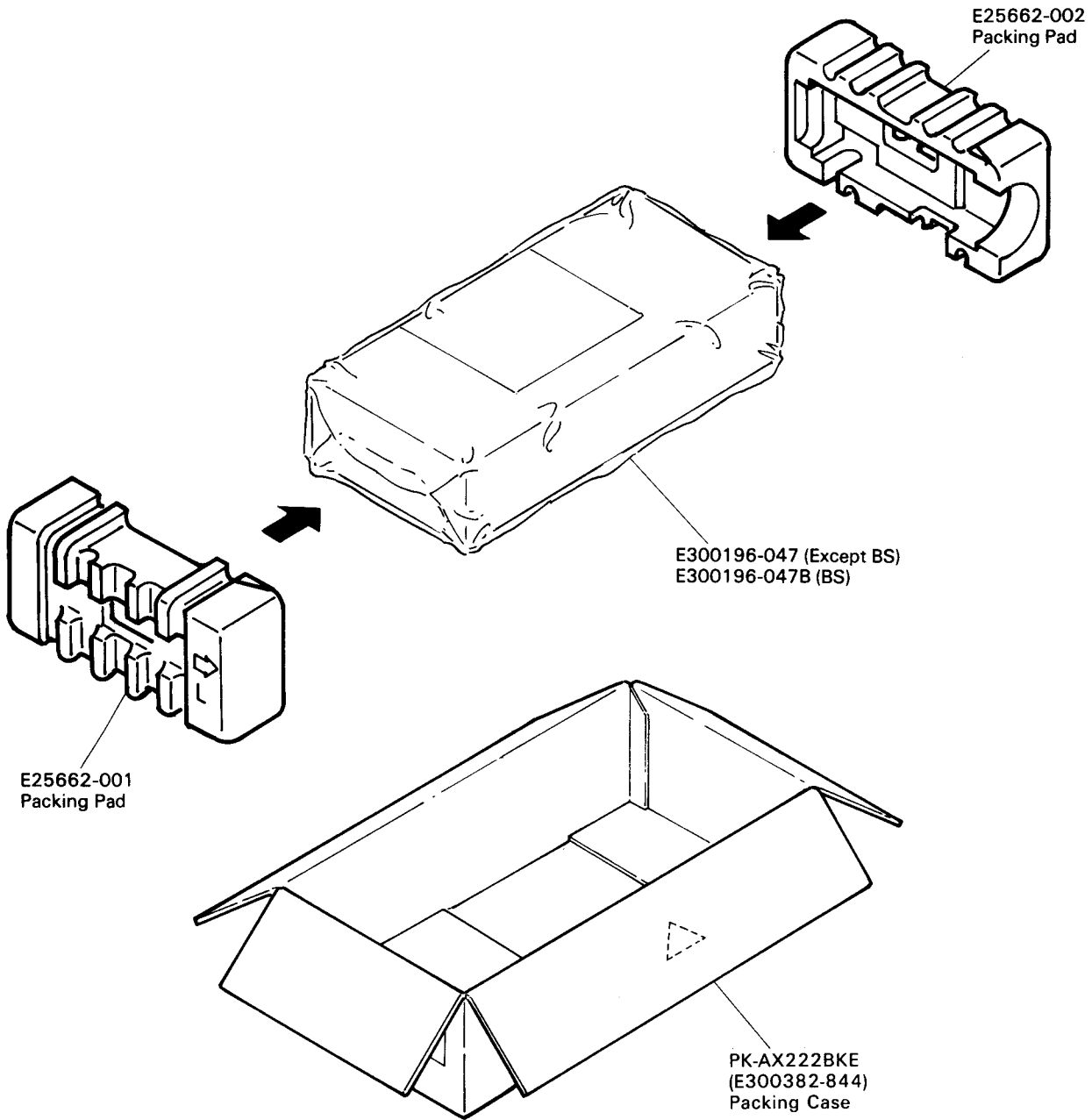

### The Marks for Designated Areas

- E.....Europe
- A.....Australia
- G.....West Germany
- BS.....U. K.
- P,PG...U. S. Military Market
- UE.....Saudi Arabia
- U.....Other Countries

No mark indicates all areas.